

DIO6073

3-Channel PMU with 36V BUCK, 18V Boost and Super Capacitor Charger

Features

- 3 in 1, Buck, Boost and Super Capacitor Charger
- Buck wide working range: 5V-36V, 42V input standoff
- Output Power for Buck: 3.3V/500mA
- Output Power for Boost at 2.5V input: 12V/500mA
- Accuracy for Charger CV voltage: 1%
- Constant charge current: 100mA
- High Efficiency PFM mode at light load
- Enable pin to auto-switch boost and charger
- Package: EP-SOIC8 and QFN3*4-24

Descriptions

The DIO6073 is a three-channel PMU, including a 36V input, high efficiency synchronous buck converter, a low startup, high efficiency 18V boost converter and a super capacitor Charger. The buck converter withstands input voltage up to 42V and provides a 3.3V output with up to 500mA current. The boost converter can provide output of up to 500mA to 12V from a single cell super capacitor or a battery at 2.5V. A linear super capacitor charger also integrates a very high accuracy CV voltage. The output voltage of boost can be adjusted by external resistor divider.

All three power modules are packaged in EP-SOIC8 and QFN3*4-24 packages.

Applications

- Power Meters
- PLC modules
- Any system that needs super capacitor as a backup power

Typical Application

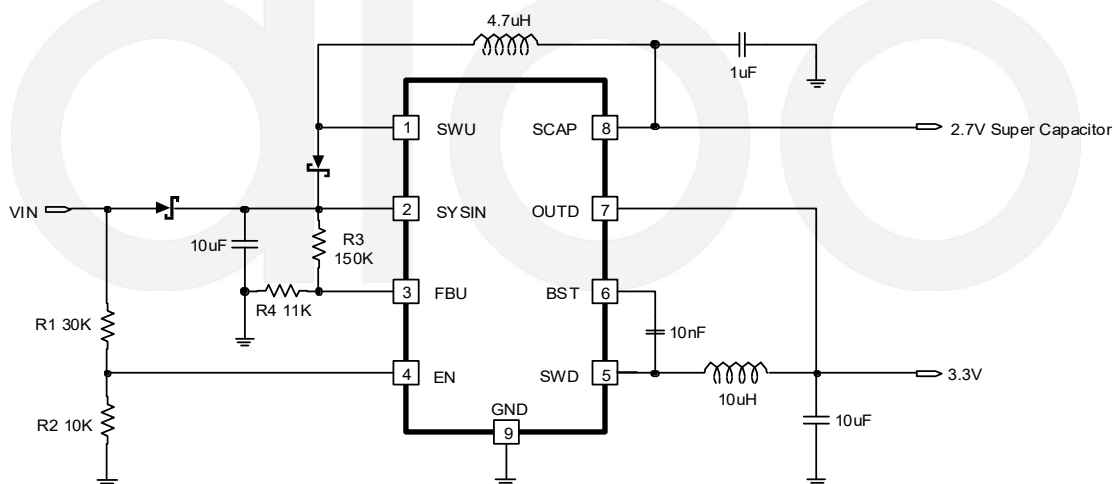

Ordering Information

Order Part Number	Top Marking		T _A	Package	
DIO6073XS8	DIOFVG3	Green	-40 to 85°C	EP-SOIC8	Tape & Reel, 2500
DIO6073QN24	DFVG3	Green	-40 to 85°C	QFN3*4-24	Tape & Reel, 5000

Pin Assignment

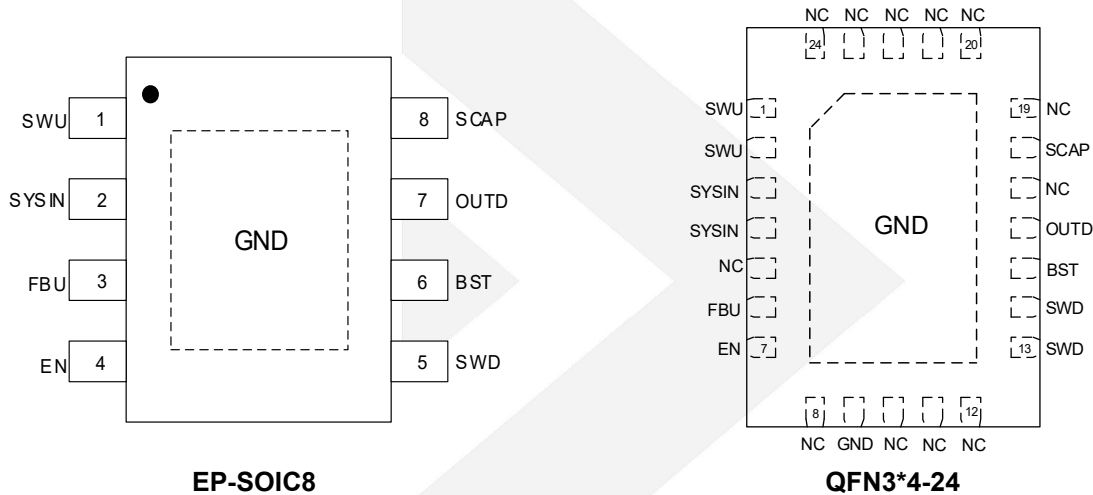

Pin Descriptions

Pin Name	Description
SWU	Switch pin for BOOST.
SYSIN	System Power input pin.
FBU	External Feedback pin for BOOST.
EN	Enable pin for auto-switching BOOST and Charger. EN=0, BOOST is ON and Charger is OFF; EN=1, Charger is ON and BOOST is OFF.
SWD	Switch pin for BUCK.
BST	Bootstrap pin for BUCK. Connect a 10nF or bigger cap from BST to SWD.
OUTD	Output voltage pin for BUCK. It is internally set to 3.3V. It is also the input of CHARGER.
SCAP	Super capacitor output. It is internally programmed to CV at 2.55V.
GND	Ground.
NC	Not Connected.

Absolute Maximum Ratings

Stresses beyond those listed under "Absolute Maximum Rating" may cause permanent damage to the device. These are stress ratings only and functional operation of the device at these or any other condition beyond those indicated in the operational sections of the specifications is not implied. Exposure to absolute maximum rating conditions for extended periods may affect device reliability.

Parameter		Rating	Unit	
SYSIN Voltage		-0.3 to 42	V	
SWD, EN Voltage		-0.3 to SYSIN+0.3	V	
SWU Voltage		-0.3 to 18	V	
BST to SWD Voltage		-0.3 to 6	V	
All Other Pin Voltage		-0.3 to 6	V	
Operating Temperature Range		-40 to 85	°C	
Storage Temperature Range		-65 to 150	°C	
Thermal Resistance	EP-SOIC8	Θ_{JC}	15	°C/W
		Θ_{JA}	50	°C/W
	QFN3*4-24	Θ_{JC}	12	°C/W
		Θ_{JA}	52	°C/W
Lead Temperature(Soldering, 10sec)		260	°C	
ESD	HBM	2	kV	



Electrical Characteristics

$V_{IN} = 12V$, unless otherwise noted. Typical values are at $T_A = 25^\circ C$.

Parameter	Conditions	Min.	Typ.	Max.	Unit
BUCK					
Buck Input Standoff Voltage		42			V
Buck Input Voltage Range		5		36	V
Buck Input UVLO Rising			4.9		V
Buck Input UVLO Falling			4.1		V
Buck Input OVP	Rising, Hysteresis=1V		37		V
V_{OUTD} Voltage	Internally SET	3.233	3.300	3.370	V
Buck Switching Frequency			630		kHz
High side Switch On Resistance	$I_{SWD}=100mA$		600		m Ω
Low side switch On Resistance	$I_{SWD}=100mA$		330		m Ω
High side Switch Current Limit			1		A
Low side Zero Crossing limit			30		mA
BOOST					
Boost Input Range		0.75		6	V
FBU Feedback Voltage		784	800	816	mV
FBU Input Current	$V_{FBU}=0$ or 2V			100	nA
Boost Output Voltage Range		3		24	V
Boost Switching Frequency			1		MHZ
Maximum Duty Cycle		92			%
NMOS Switch On Resistance	$I_{SWU}=100mA$		80		m Ω
NMOS Switch Current Limit			4		A
SWU Leakage Current	$V_{SWU}=0$ or 12V, $V_{EN}=GND$			10	μA
CHARGER					
CV voltage		2.52	2.55	2.58	V
Charge current			100		mA
Dropout voltage	$I_{OUT}=30mA$		50		mV
SYSTEM					
Quiescent current of SYSIN at EN=0	$V_{FBU}=0.9V$, $V_{OUTD}=3.6V$		750		μA
Quiescent current of SYSIN at EN=1	$V_{FBU}=0.9V$, $V_{OUTD}=3.6V$, $V_{SCAP}=3V$		500		μA
EN input current	$V_{EN}=12V$		5		μA
EN threshold	Rising, Hysteresis=0.2V		1.5		V
Thermal shutdown	Rising, Hysteresis=40 $^\circ C$		150		$^\circ C$

Functional Block Diagram

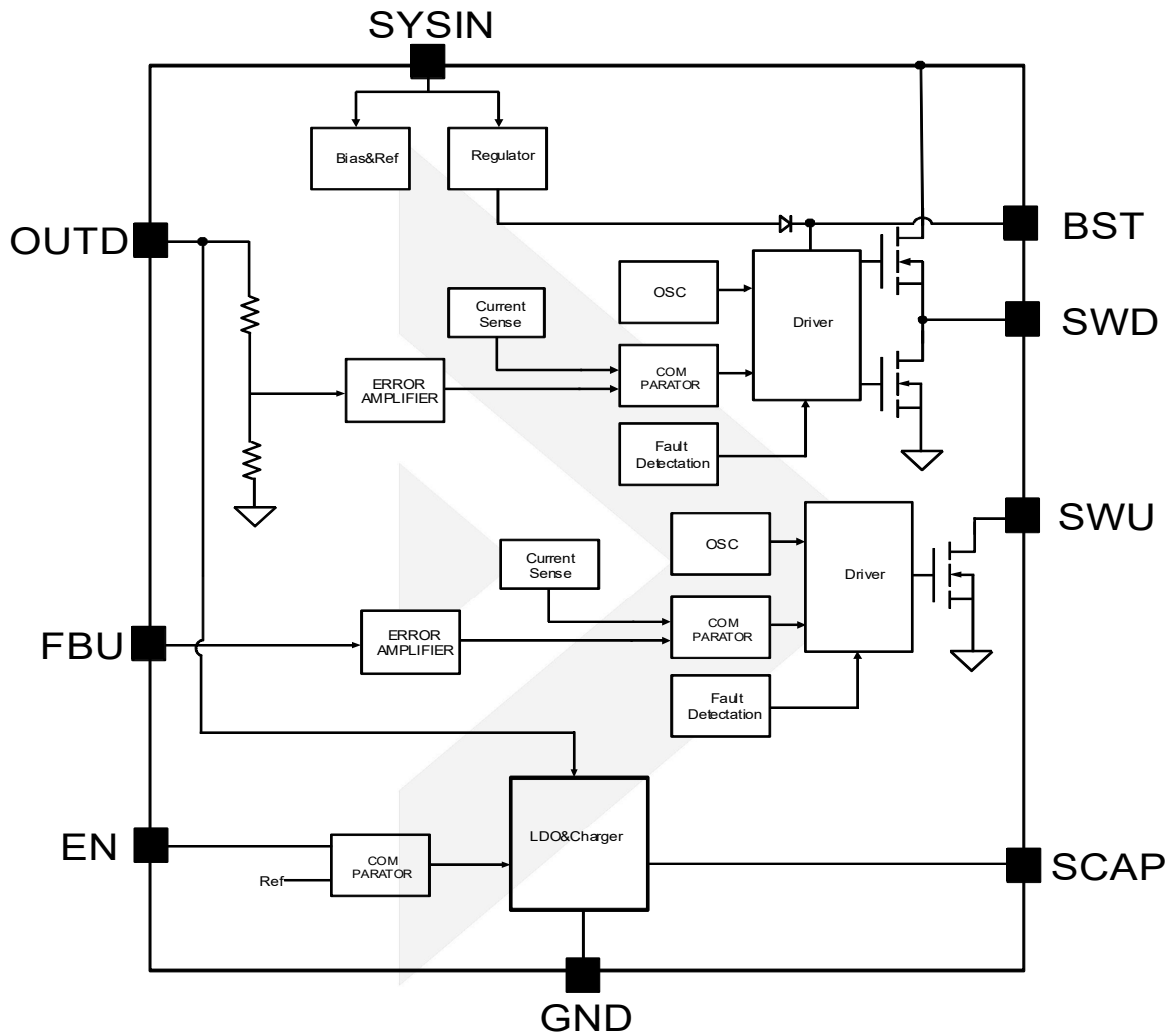

Functional Description

The DIO6073 is a three-channel PMU that includes a wide input, high efficiency synchronous buck converter, a low startup, high efficiency boost converter and a super capacitor Charger. The buck converter withstands input voltage up to 42V and delivers a 3.3V output with up to 500mA current. The boost converter is capable of providing up to 500mA to 12V output from a single cell super capacitor or a battery at 2.5V. A linear super capacitor charger is also integrated with a very high accuracy CV voltage. The output voltage of boost can be adjusted by external resistor divider.

Buck converter

The Buck is a wide input range, high-efficiency, synchronous step-down switching regulator which output is fixed at 3.3V, capable of delivering up to 0.5A of output current. With a fixed switching frequency of 630KHz, this current mode PWM controlled converter allows the use of small external components, such as ceramic input and output caps, as well as small inductors. An OVP function protects the IC itself and its downstream system against input voltage surges. With this OVP function, the IC can stand off input voltage as high as 42V.

Boost converter

The BOOST is a high efficiency no-synchronous step up converter. It is capable of delivering at least 6W of power from 2.5V, eg: 0.5A at 12V output. A switching frequency of 1MHz minimizes solution footprint by allowing the use of tiny and low-profile inductors and ceramic capacitors. The output of BOOST can be set by external resistor divider at FBU pin.

Charger

The CHARGER is fully integrated constant current (CC) / constant voltage (CV) function. It can deliver up to 100mA of charge current with a final float voltage of 1%.

Enable

EN is a digital control pin that turns the BOOST and CHARGER on and off. Drive EN High to turn on the CHARGER and turn off the BOOST, drive it Low to turn off the CHARGER and turn on the BOOST.

Over-Temperature Protection

Thermal protection disables BUCK, BOOST and CHARGER when the junction temperature rises to approximately 150°C, allowing the device to cool down. When the junction temperature cools to approximately 135°C, the output circuitry is again enabled. Depending on power dissipation, thermal resistance, and ambient temperature, the thermal protection circuit may cycle on and off. This cycling limits regulator dissipation, protecting the device from damage as a result of overheating.

Application Information**BOOST Output Voltage Setting**

The DIO6073 BOOST OUTPUT is programmed using an external resistor divider. The output voltage is calculated using below equation.

$$V_{OUT} = V_{REF} * (1 + \frac{R3}{R4})$$

Where: V_{REF} = 0.8V typically, Resistors R4 is the resistor between FBU and GND and R3 is the one between output and FBU pin. R4 has to be between 1kΩ to 20kΩ and thus R3 is calculated by following equation.

$$R3 = (\frac{V_{OUT}}{V_{REF}} - 1) * R4$$

BOOST and Super-Capacitor Charger Auto-Switching Threshold Voltage Setting

The DIO6073's EN pin also serves as a threshold voltage for auto-switching Super Capacitor Charger and the Boost. When the VIN drops, and EN's voltage is below the falling threshold voltage (1.3V), the super-capacitor charger is disabled and the boost converter is then enabled at the same time. With a resistor ladder, R1 from VIN to EN and R2 from EN to GND, the VIN dropping threshold thus is programmed by the equation below.

$$V_{INThreshold} = 1.3 * (1 + \frac{R1}{R2})$$

R2 has to be between 1kΩ to 20kΩ and thus R1 is calculated by following equation.

$$R1 = (\frac{V_{INThreshold}}{1.3} - 1) * R2$$

Typical Performance Characteristics

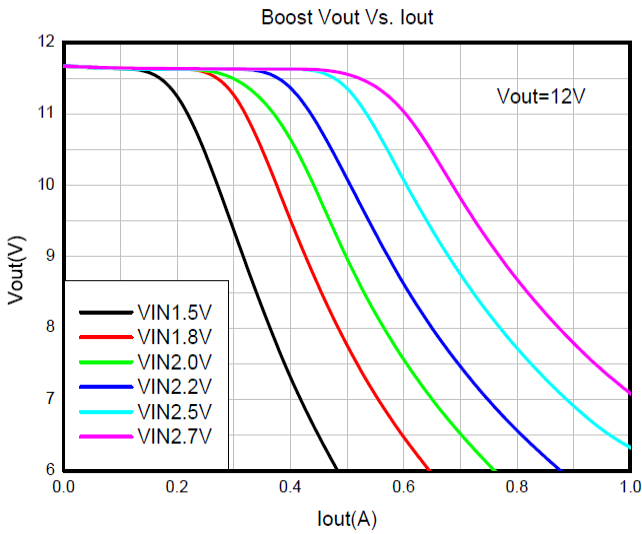

Figure 2 Boost Vout Vs. Iout

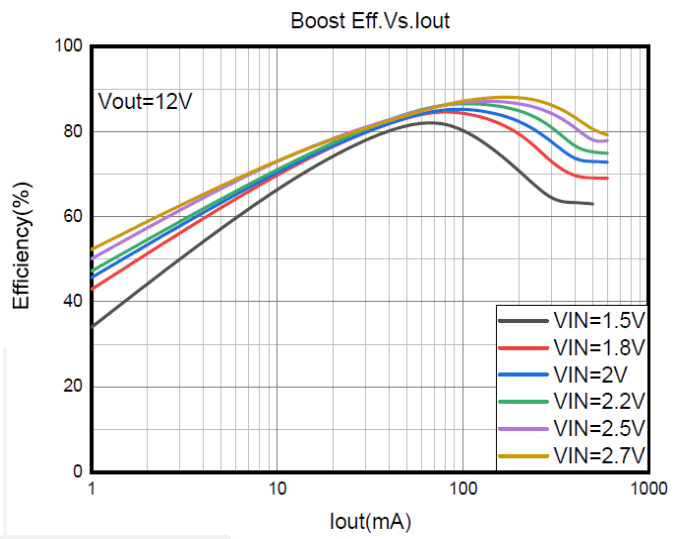

Figure 3 Boost Eff.Vs.Iout

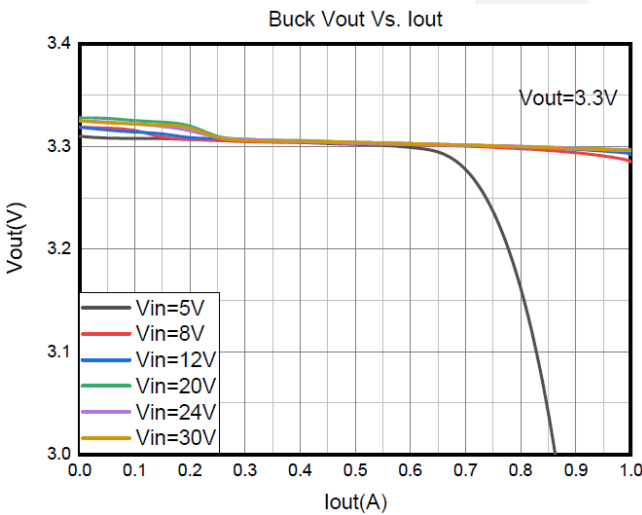

Figure 4 Buck Vout Vs. Iout

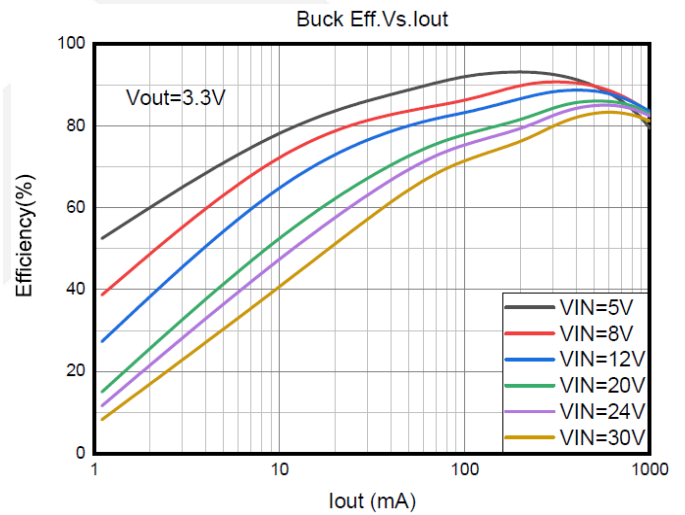

Figure 5 Buck Eff.Vs.Iout

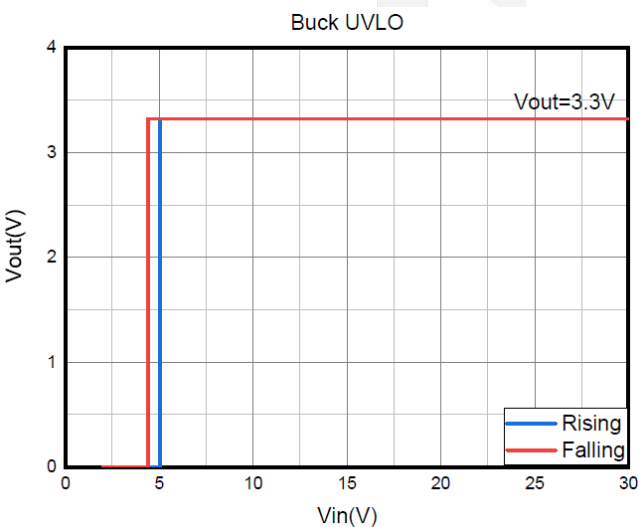

Figure 6 Buck UVLO

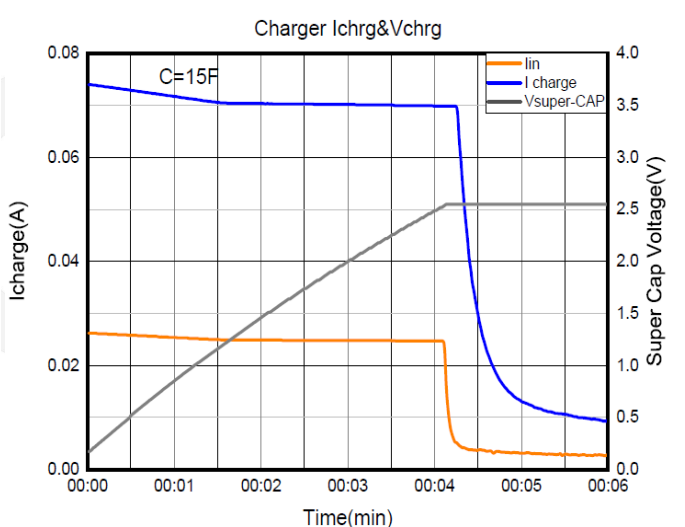

Figure 7 Charger Icharg&chrg

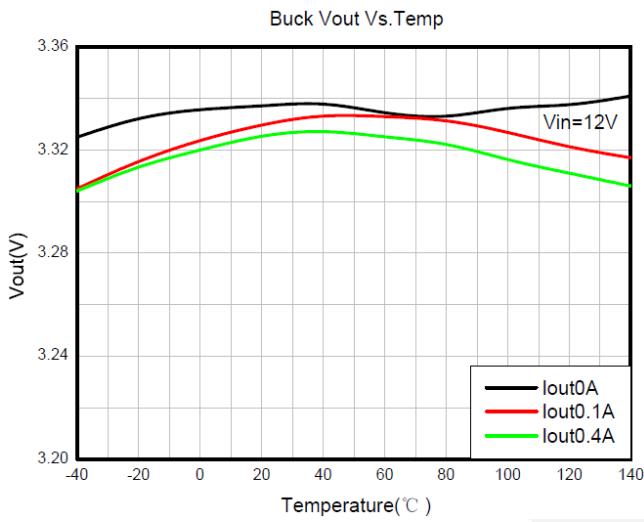

Figure 8 Buck Vout Vs.Temp

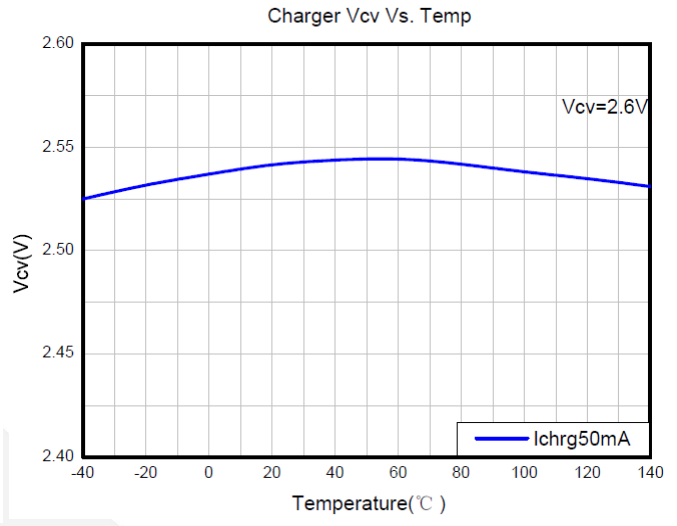

Figure 9 Charger Vcv Vs.Temp

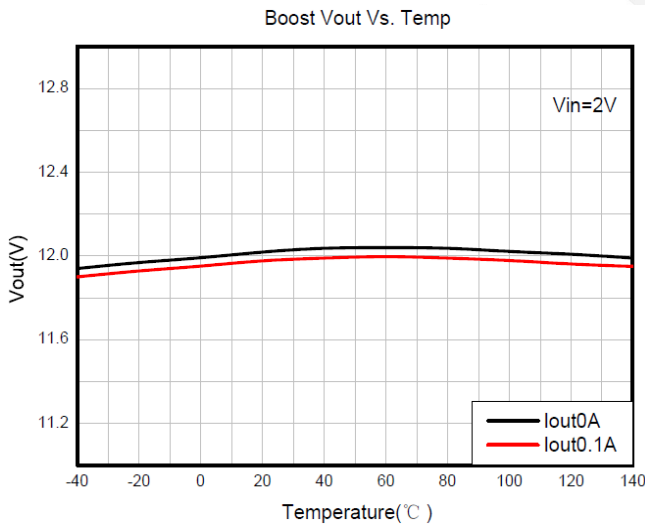

Figure 10 Boost Vout Vs.Temp

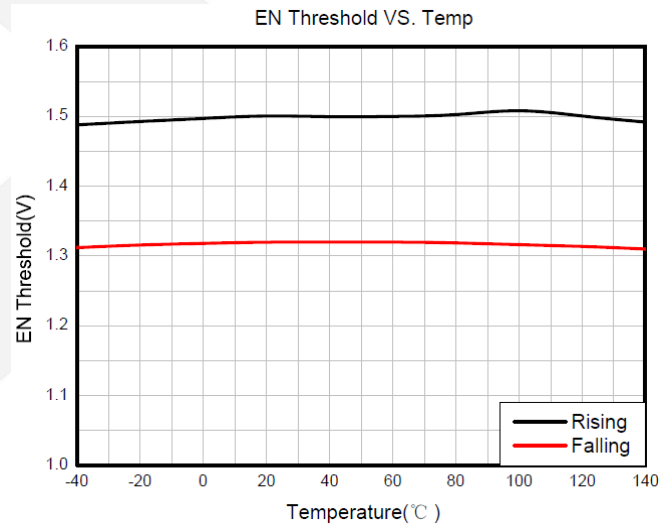

Figure 11 EN Threshold Vs.Temp



CONTACT US

Dioo is a professional design and sales corporation for high-quality and performance analog semiconductors. The company focuses on industry markets, such as, cell phone, handheld products, laptop, and medical equipment and so on. Dioo's product families include analog signal processing and amplifying, LED drivers and charger IC. Go to <http://www.dioo.com> for a complete list of Dioo product families.

For additional product information, or full datasheet, please contact with our Sales Department or Representatives.

