

# 4.5Ω Low Voltage Dual SPDT Analog Switch

## FEATURES

- **High Bandwidth: 300MHz**
- **High Speed, Typically 30ns**
- **Supply Range: +1.8V to +5.5V**
- **Low ON-State Resistance, 4.5Ω(TYP)**
- **Break-Before-Make Switching**
- **Rail-to-Rail Operation**
- **TTL/CMOS Compatible**
- **Extended Industrial Temperature Range: -40°C to +125°C**

## APPLICATIONS

- **Wearable Devices**
- **Battery-Operated Equipment**
- **Signal Gating, Chopping, Modulation or Demodulation (Modem)**
- **Portable Computing**
- **Cell Phones**

## FUNCTION TABLE

LOGIC	NO1, NO2	NC1, NC2
0	OFF	ON
1	ON	OFF

## PIN DESCRIPTION

NAME	PIN	FUNCTION
COM1, COM2	1, 3	Common Terminal
NC1, NC2	2, 4	Normally-Closed Terminal
GND	5	Ground
IN2, IN1	6, 8	Digital Control Pin
NO2, NO1	7, 9	Normally-Open Terminal
V+	10	Power Supply

## DESCRIPTION

The RS2058 is a dual, single-pole double-throw (SPDT) analog switch that is designed to operate from 1.8 V to 5.5 V.

The RS2058 device can handle both analog and digital signals. It features high-bandwidth(300MHz) and low on-resistance (4.5 Ω TYP).

Applications include signal gating, chopping, modulation or demodulation (modem), and signal multiplexing for analog-to-digital and digital-to-analog conversion systems.

## PIN CONFIGURATIONS

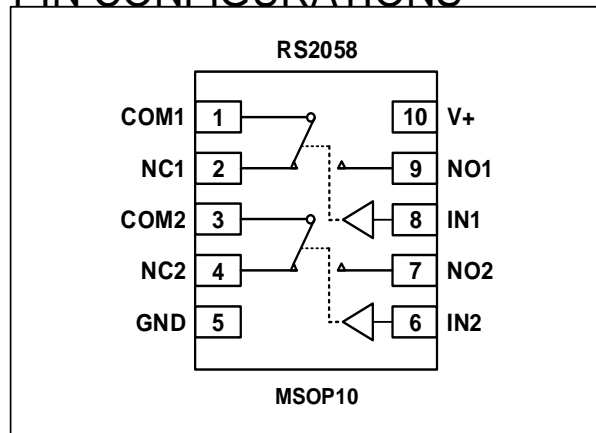

PIN CONFIGURATIONS

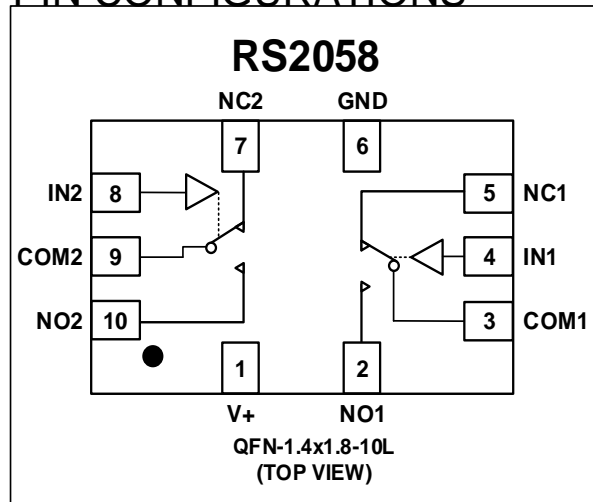

NAME	PIN	FUNCTION
V+	1	Power Supply
NO1, NO2	2, 10	Normally-Open Terminal
COM1, COM2	3, 9	Common Terminal
IN1, IN2	4, 8	Digital Control Pin
NC1, NC2	5, 7	Normally-Closed Terminal
GND	6	Ground

### ABSOLUTE MAXIMUM RATINGS <sup>(1)</sup>

V+, IN to GND.....	-0.3V to 6.0V
Analog, Digital Voltage Range <sup>(2)</sup> .....	- 0.3 to (V+) + 0.3V
Continuous Current NO, NC, or COM.....	±300mA
Peak Current NO, NC, or COM.....	±500mA
Storage Temperature .....	-65°C to +150°C
Operating Temperature .....	-40°C to +125°C
Junction Temperature.....	150°C
Package Thermal Resistance @ T <sub>A</sub> = +25°C	
MSOP-10.....	204°C/W
Lead Temperature (Soldering, 10s) .....	260°C
ESD Susceptibility	
HBM .....	1000V
MM .....	100V



### ESD SENSITIVITY CAUTION

ESD damage can range from subtle performance degradation to complete device failure. Precision integrated circuits may be more susceptible to damage because very small parametric changes could cause the device not to meet its published specifications.

- (1) Stresses above these ratings may cause permanent damage. Exposure to absolute maximum conditions for extended periods may degrade device reliability. These are stress ratings only, and functional operation of the device at these or any other conditions beyond those specified is not implied.
- (2) Input terminals are diode-clamped to the power-supply rails. Input signals that can swing more than 0.3V beyond the supply rails should be current-limited to 10mA or less.

### PACKAGE/ORDERING INFORMATION

PRODUCT	ORDERING NUMBER	TEMPERATURE RANGE	PACKAGE LEAD	PACKAGE MARKING	PACKAGE OPTION
RS2058	RS2058XN	-40°C~125°C	MSOP-10	RS2058	Tape and Reel,3000
RS2058	RS2058XUTQK10	-40°C ~125°C	QFN-1.4x1.8-10L	2058X	Tape and Reel,4000

NOTE: X = Date Code

### MARKING INFORMATION

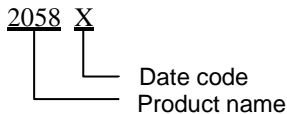

**ELECTRICAL CHARACTERISTICS**
 $V+ = 5.0\text{ V}$ ,  $T_A = -40^\circ\text{C}$  to  $125^\circ\text{C}$  (unless otherwise noted)

PARAMETER	SYMBOL	CONDITIONS	V+	T <sub>A</sub>	MIN	TYP	MAX	UNITS
<b>ANALOG SWITCH</b>								
Analog Signal Range	$V_{NO}$ , $V_{NC}$ , $V_{COM}$			FULL	0		$V+$	V
On-Resistance	$R_{ON}$	$V_{NO}$ or $V_{NC} = V+/2$ , $I_{COM} = -10\text{mA}$ , Switch ON, See Figure 1	5V	+25°C		4.5	8	$\Omega$
				FULL			8.5	$\Omega$
			3.3V	+25°C		7	10	$\Omega$
				FULL			10.5	$\Omega$
On-Resistance Match Between Channels	$R_{ON}$	$V_{NO}$ or $V_{NC} = V+/2$ , $I_{COM} = -10\text{mA}$ , Switch ON, See Figure 1	5V	+25°C		0.15	0.3	$\Omega$
				FULL			0.4	$\Omega$
			3.3V	+25°C		0.15	0.3	$\Omega$
				FULL			0.4	$\Omega$
On-Resistance Flatness	$R_{FLAT(ON)}$	$0 \leq (V_{NO} \text{ or } V_{NC}) \leq V+/2$ , $I_{COM} = -10\text{mA}$ , Switch ON, See Figure 1	5V	+25°C		2	3	$\Omega$
				FULL			3.3	$\Omega$
			3.3V	+25°C		3	4	$\Omega$
				FULL			4.3	$\Omega$
NC,NO OFF Leakage Current	$I_{NC(OFF)}$ , $I_{NO(OFF)}$	$V_{NO}$ or $V_{NC} = 0.3\text{V}$ , $V+/2$ $V_{COM} = V+/2$ , $0.3\text{V}$ See Figure 2	1.8 to 5.5V	FULL			1	$\mu\text{A}$
NC,NO,COM ON Leakage Current	$I_{NC(ON)}$ , $I_{NO(ON)}$ , $I_{COM(ON)}$	$V_{NO}$ or $V_{NC} = 0.3\text{V}$ , Open $V_{COM} = \text{Open}$ , $0.3\text{V}$ See Figure 2	1.8 to 5.5V	FULL			1	$\mu\text{A}$
<b>DIGITAL CONTROL INPUTS<sup>(1)</sup></b>								
Input High Voltage	$V_{INH}$		5V	FULL	1.5			V
			3.3V	FULL	1.3			V
Input Low Voltage	$V_{INL}$		5V	FULL			0.6	V
			3.3V	FULL			0.5	V
Input Leakage Current	$I_{IN}$	$V_{IN} = V_{IO}$ or 0	1.8 to 5.5V	FULL			1	$\mu\text{A}$

(1) All unused digital inputs of the device must be held at  $V_{IO}$  or GND to ensure proper device operation.

**ELECTRICAL CHARACTERISTICS (continued)**
 $V_+ = 5.0\text{ V}$ ,  $\text{TEMP} = -40^\circ\text{C}$  to  $125^\circ\text{C}$  (unless otherwise noted)

PARAMETER	SYMBOL	CONDITIONS	V+	TEMP	MIN	TYP	MAX	UNITS
<b>DYNAMIC CHARACTERISTICS</b>								
Turn-On Time	$t_{\text{ON}}$	$V_{\text{COM}} = V_+$ , $R_L = 300\Omega$ , $C_L = 35\text{pF}$ , See Figure 5	5V	+25°C		30		ns
			3.3V			40		
Turn-Off Time	$t_{\text{OFF}}$	$V_{\text{COM}} = V_+$ , $R_L = 300\Omega$ , $C_L = 35\text{pF}$ , See Figure 5	5V	+25°C		25		ns
			3.3V			30		
Break-Before-Make Time Delay	$t_{\text{BBM}}$	$V_{\text{NO}1} = V_{\text{NC}1} = V_{\text{NO}2} = V_{\text{NC}2} = 3\text{V}$ , $R_L = 300\Omega$ , $C_L = 35\text{pF}$ , See Figure 6	5V	+25°C		5		ns
			3.3V			8		
Off Isolation	$O_{\text{ISO}}$	$R_L = 50\Omega$ , Switch OFF, See Figure 8	f = 10MHz	+25°C		-52		dB
			f = 1MHz	+25°C		-71		dB
-3dB Bandwidth	BW	Switch ON, $R_L = 50\Omega$ See Figure 7		+25°C		300		MHz
NC,NO OFF Capacitance	$C_{\text{NC(OFF)}}$ , $C_{\text{NO(OFF)}}$	$V_{\text{NC}}$ or $V_{\text{NO}} = V_+/2$ or GND, Switch OFF See Figure 4		+25°C		5		pF
NC,NO,COM ON Capacitance	$C_{\text{NC(ON)}}$ , $C_{\text{NO(ON)}}$ , $C_{\text{COM(ON)}}$	$V_{\text{NC}}$ or $V_{\text{NO}} = V_+/2$ or GND, Switch ON See Figure 4		+25°C		15		pF
<b>POWER REQUIREMENTS</b>								
Power Supply Range	$V_+$			FULL	1.8		5.5	V
Power Supply Current	$I_+$	$V_{\text{IN}} = \text{GND}$ or $V_+$	5.5V	FULL			1	$\mu\text{A}$

TYPICAL CHARACTERISTICS

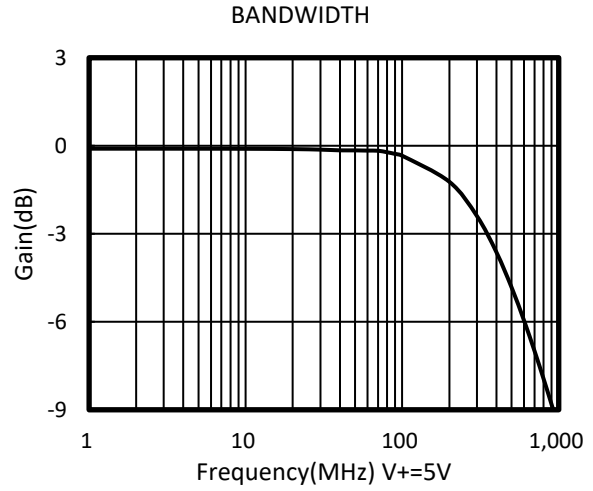
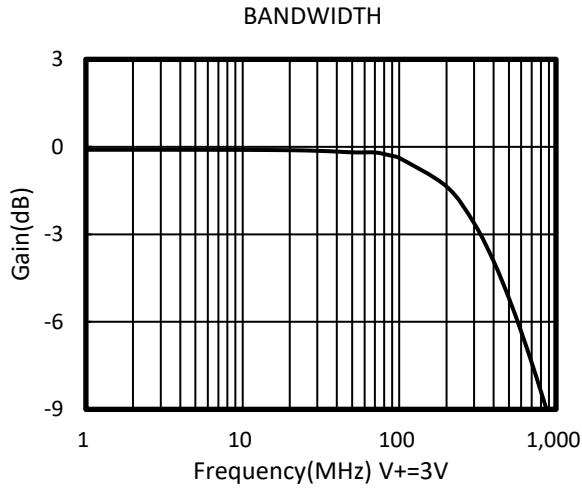

Typical  $r_{on}$  as a Function of Input Voltage ( $V_I$ ) for  $V_I = 0$  to  $V_+$

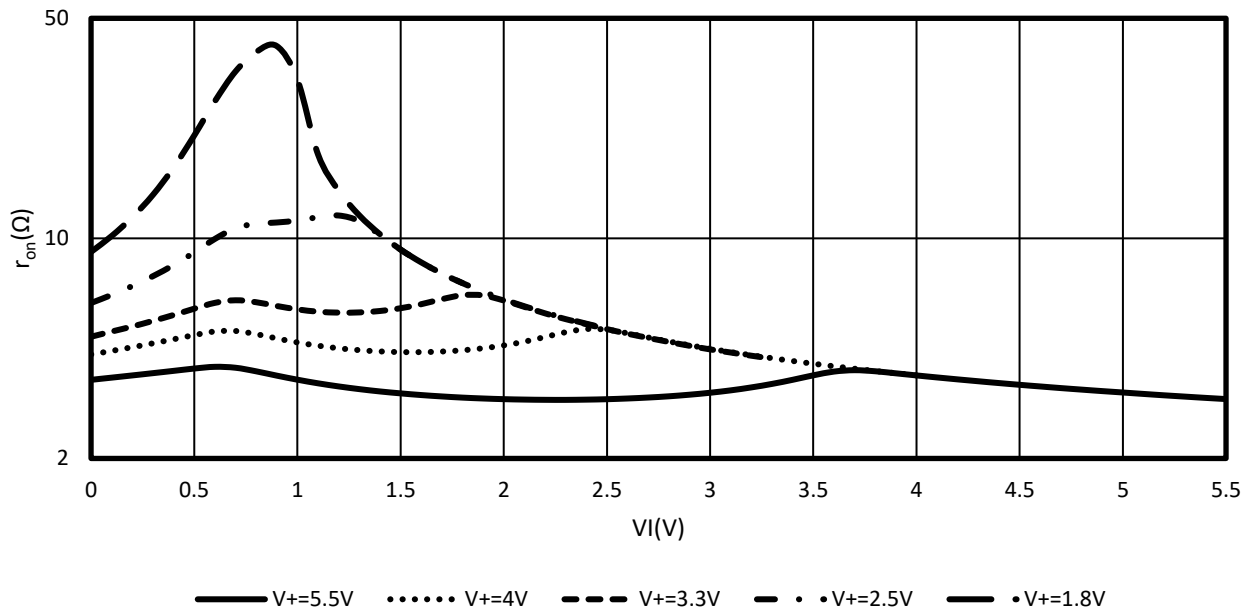

### Parameter Measurement Information

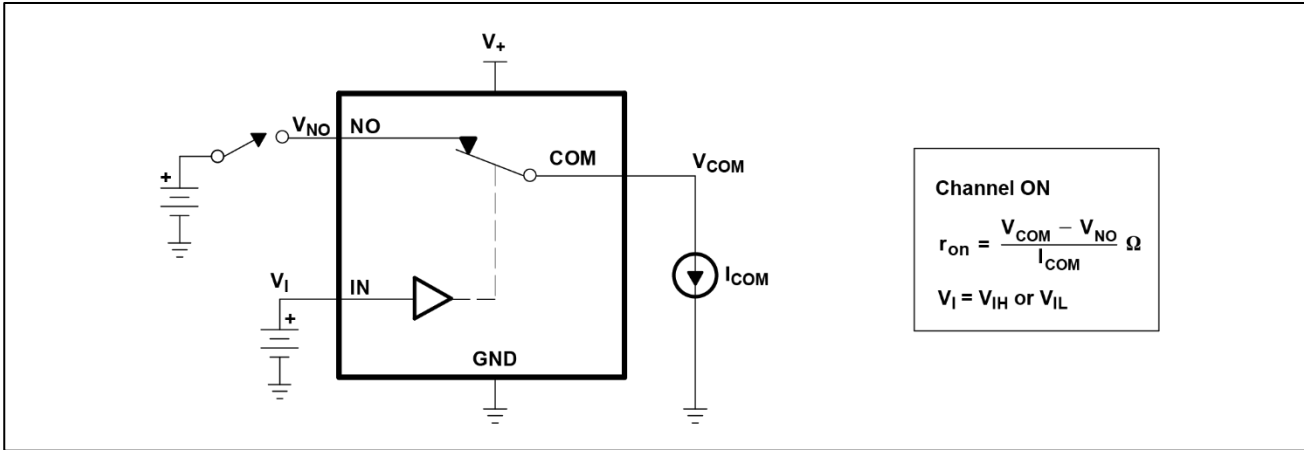

Figure 1.ON-State Resistance ( $r_{on}$ )

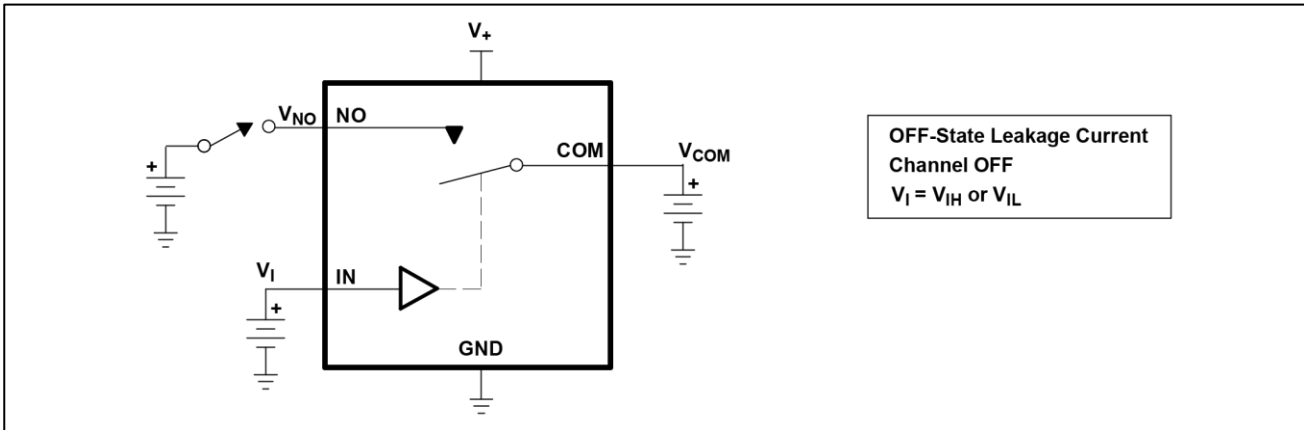

Figure 2.OFF-State Leakage Current ( $I_{COM(OFF)}$ ,  $I_{NO(OFF)}$ )

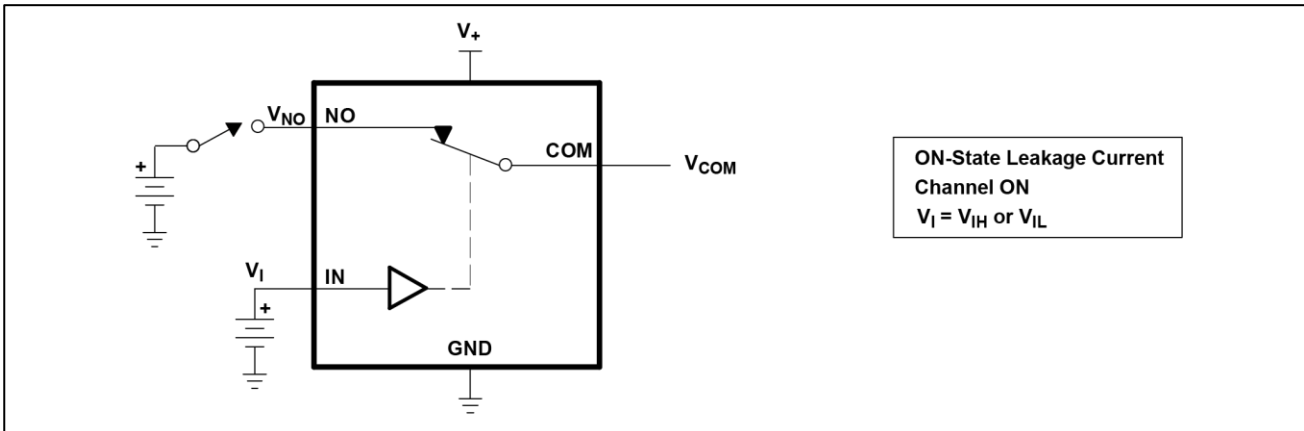

Figure 3.ON-State Leakage Current ( $I_{COM(ON)}$ ,  $I_{NO(ON)}$ )

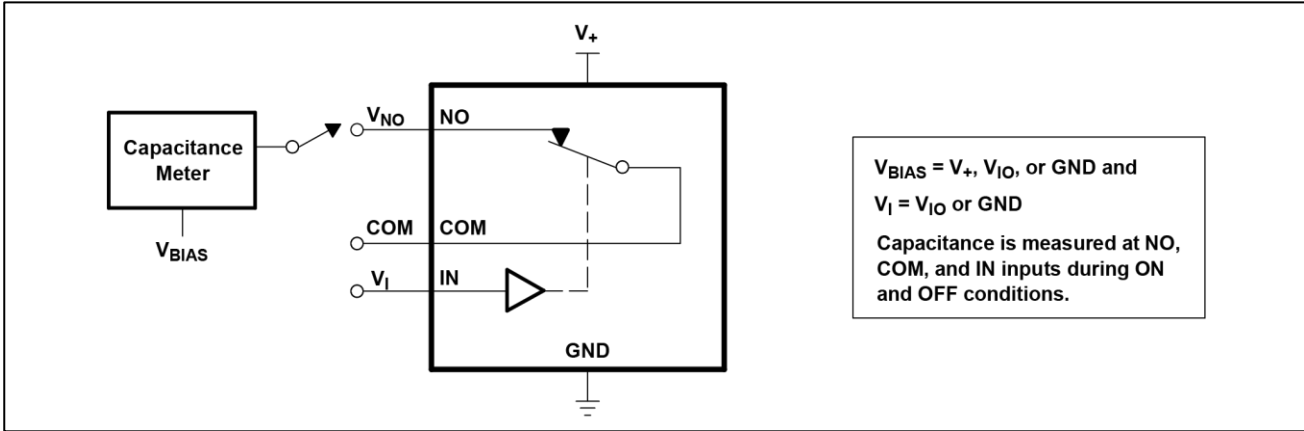

Figure 4. Capacitance ( $C_I$ ,  $C_{COM(OFF)}$ ,  $C_{COM(ON)}$ ,  $C_{NO(OFF)}$ ,  $C_{NO(ON)}$ )

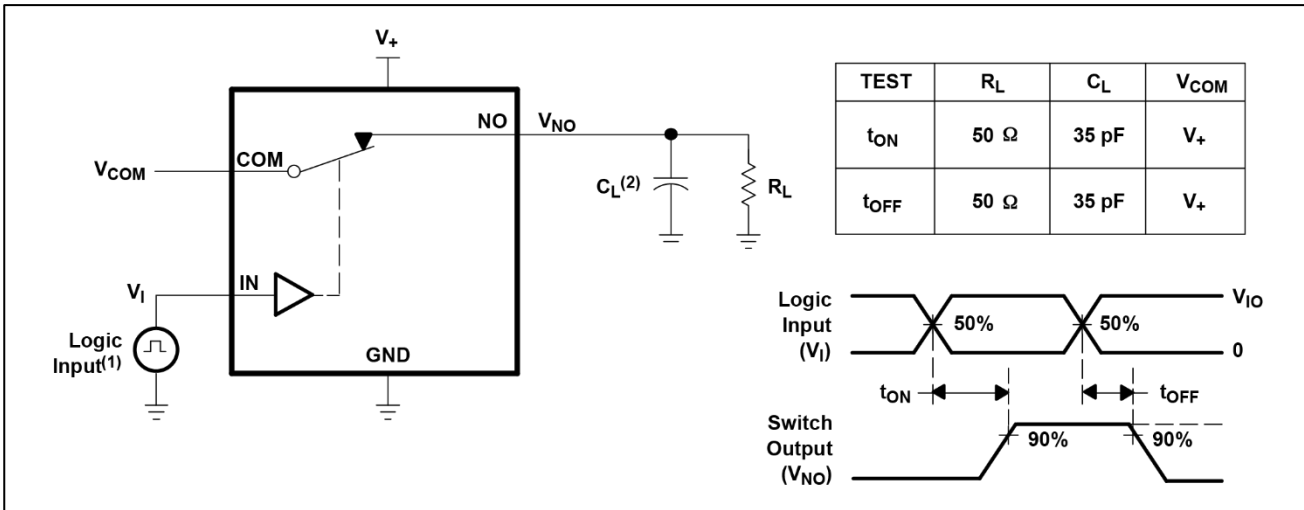

Figure 5. Turn-On ( $t_{ON}$ ) and Turn-Off Time ( $t_{OFF}$ )

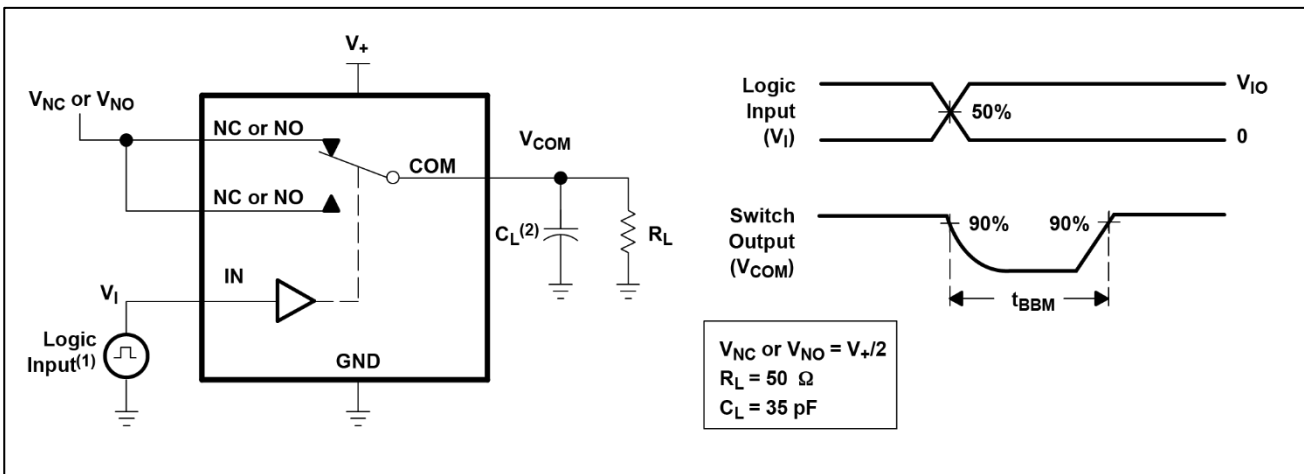

Figure 6. Break-Before-Make Time ( $t_{BBM}$ )



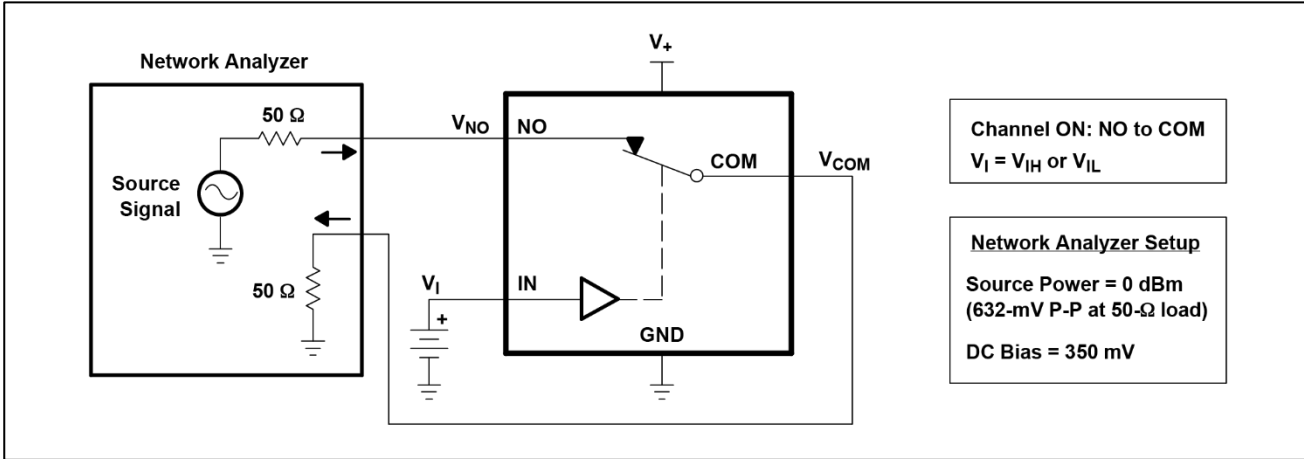

Figure 7. Bandwidth (BW)

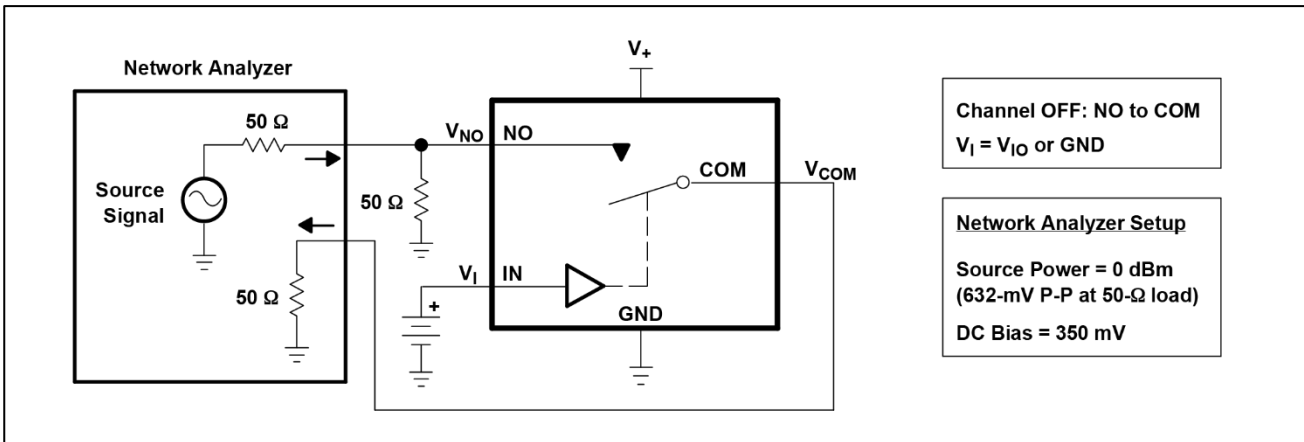

Figure 8. OFF Isolation ( $O_{iso}$ )

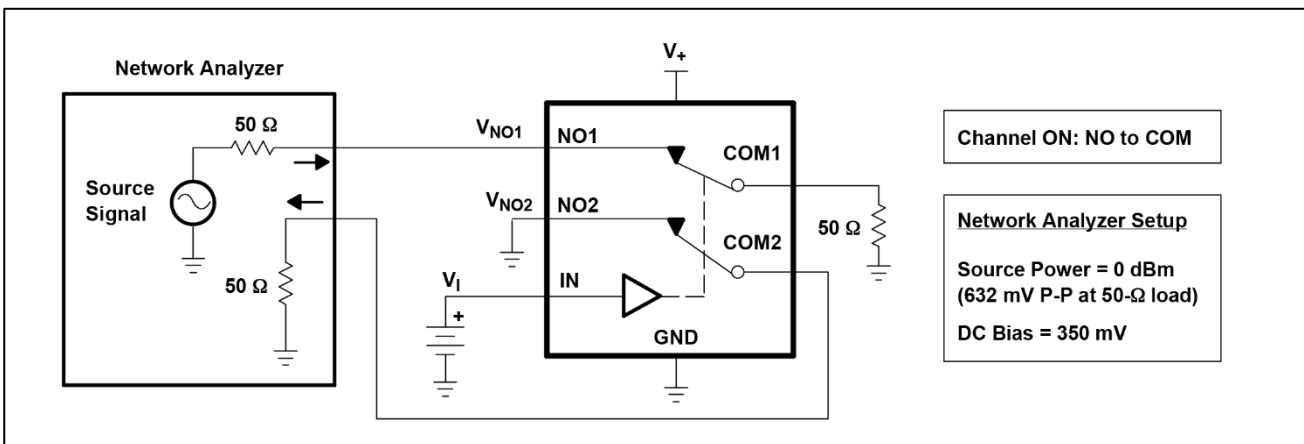

Figure 9. Crosstalk ( $X_{TALK}$ )

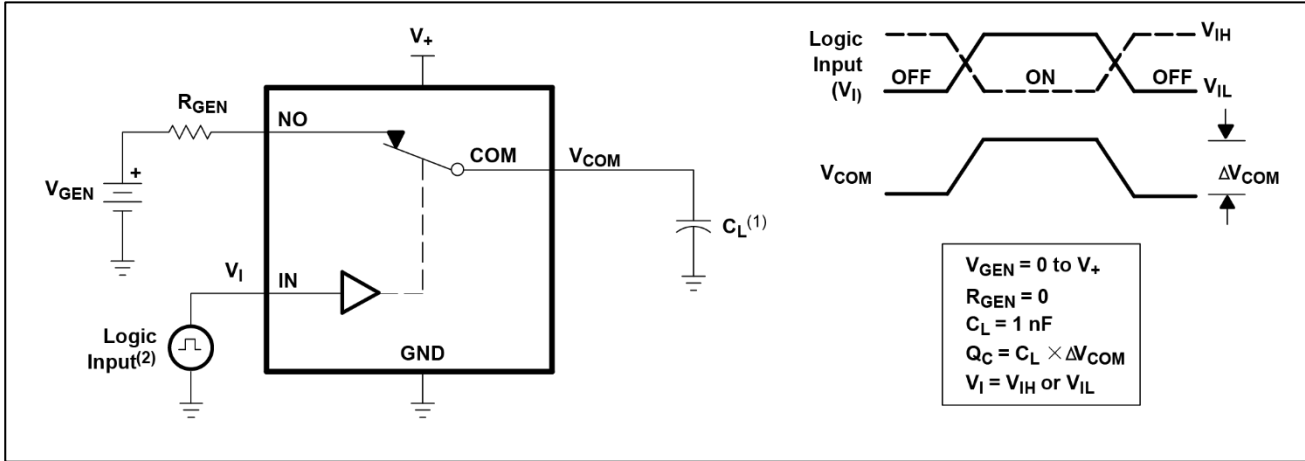

Figure 10. Charge Injection ( $Q_C$ )

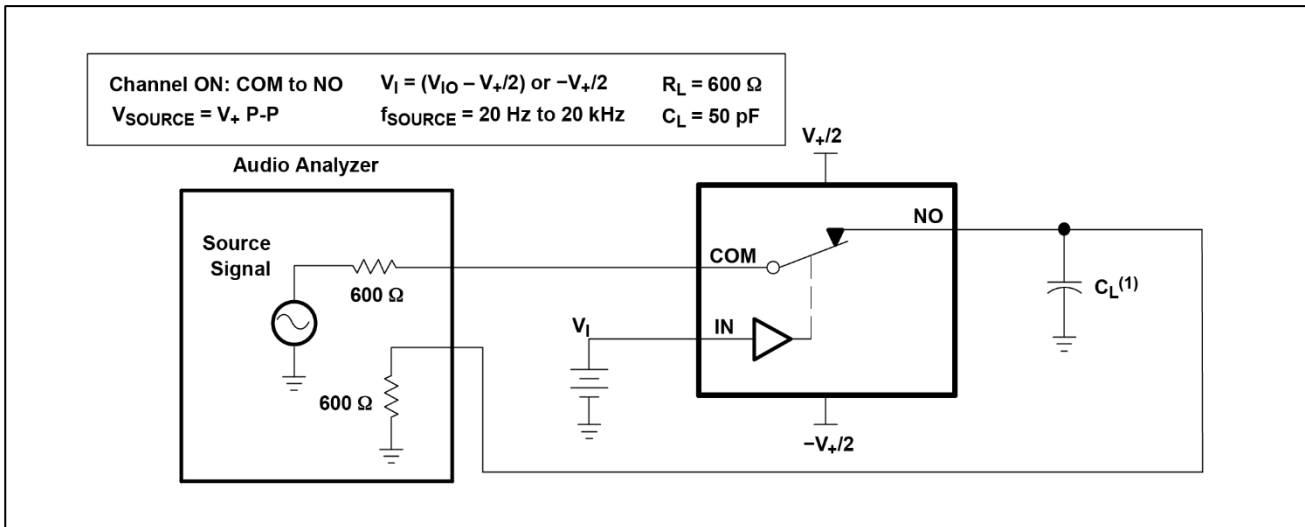
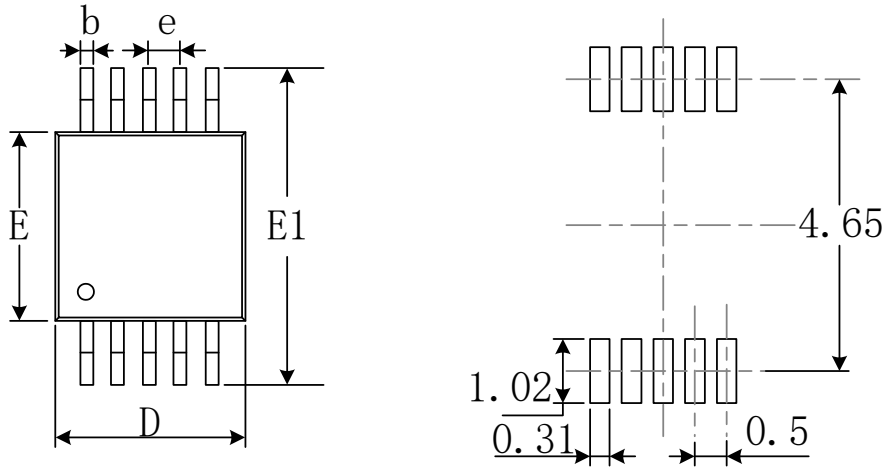

Figure 11. Total Harmonic Distortion (THD)

# PACKAGE OUTLINE DIMENSIONS

## MSOP-10



RECOMMENDED LAND PATTERN (Unit: mm)

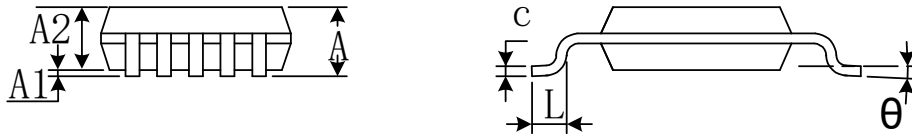

Symbol	Dimensions In Millimeters		Dimensions In Inches	
	Min	Max	Min	Max
A	0.820	1.100	0.032	0.043
A1	0.020	0.150	0.001	0.006
A2	0.750	0.950	0.030	0.037
b	0.180	0.280	0.007	0.011
c	0.090	0.230	0.004	0.009
D	2.900	3.100	0.114	0.122
e	0.50(BSC)		0.020(BSC)	
E	2.900	3.100	0.114	0.122
E1	4.750	5.050	0.187	0.199
L	0.400	0.800	0.016	0.031
$\theta$	0°	6°	0°	6°

# QFN-1.4x1.8-10L

