

0.6Ω Quad SPDT Analog Switch 4-Channel 2:1 Multiplexer – Demultiplexer With Two Controls

FEATURES

- **Bandwidth: 30MHz**
- **High Speed, Typically 50ns**
- **Supply Range: +1.8V to +5.5V**
- **Low ON-State Resistance, 0.6Ω(TYP)**
- **Break-Before-Make Switching**
- **Rail-to-Rail Operation**
- **TTL/CMOS Compatible**
- **Extended Industrial Temperature Range: -40°C to +125°C**

APPLICATIONS

- **Video Switching**
- **Relay Replacements**
- **USB Switching**
- **Battery-Operated Equipment**
- **Cell Phones**

FUNCTION TABLE

IN1-2	NO1 and NO2	NC1 and NC2
0	OFF	ON
1	ON	OFF

IN3-4	NO3 and NO4	NC3 and NC4
0	OFF	ON
1	ON	OFF

DESCRIPTION

The RS2099 is a bidirectional 4-channel single-pole double-throw (SPDT) analog switch with two control inputs, which is designed to operate from 1.8V to 5.5V. This device is also known as a 2 channels double-pole double-throw (DPDT) configuration.

The RS2099 device can handle both analog and digital signals. It features bandwidth(30MHz) and low on-resistance (0.6Ω TYP).

Applications include signal gating, chopping, modulation or demodulation (modem), and signal multiplexing for analog-to-digital and digital-to-analog conversion systems.

PIN CONFIGURATIONS

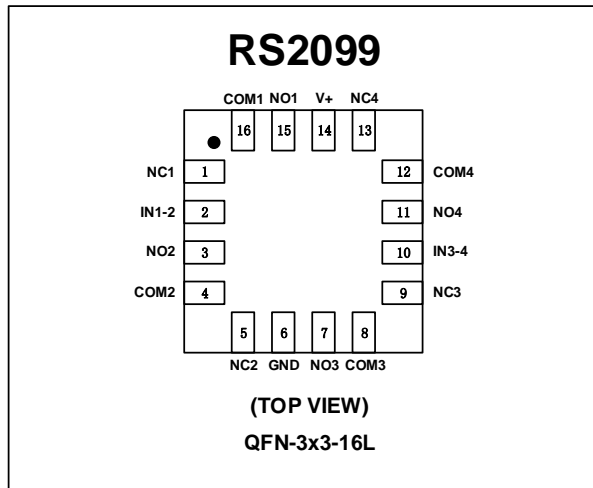

PIN DESCRIPTION

NAME	PIN	FUNCTION
V+	14	Power Supply
GND	6	Ground
IN1-2	2	Digital Control Pin
IN3-4	10	Digital Control Pin
COMx	16,4,8,12	Common Terminal
NOx	15,3,7,11	Normally-Open Terminal
NCx	1,5,9,13	Normally-Closed Terminal

PIN CONFIGURATIONS

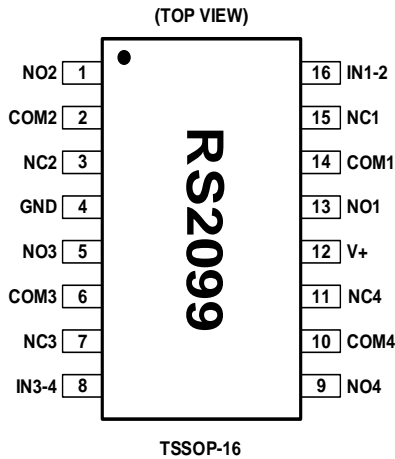

PIN DESCRIPTION

NAME	PIN	FUNCTION
V+	12	Power Supply
GND	4	Ground
IN1-2	16	Digital Control Pin
IN3-4	8	Digital Control Pin
COMx	2,6,10,14	Common Terminal
NOx	1,5,9,13	Normally-Open Terminal
NCx	3,7,11,15	Normally-Closed Terminal

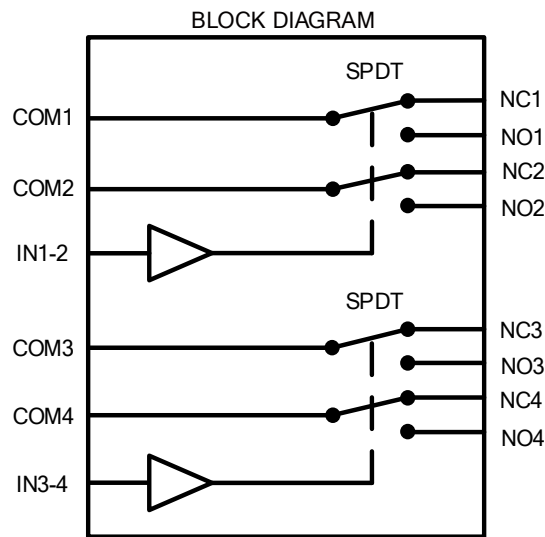

ABSOLUTE MAXIMUM RATINGS (1)

V+, IN to GND.....	-0.3V to 6.0V
Analog, Digital Voltage Range (2)	- 0.3 to (V+) + 0.3V
Continuous Current NO, NC, or COM.....	±500mA
Peak Current NO, NC, or COM.....	±800mA
Storage Temperature	-65°C to +150°C
Operating Temperature	-40°C to +125°C
Junction Temperature.....	150°C
Package Thermal Resistance @ TA = +25°C	
TSSOP-16.....	110°C/W
QFN-3x3-16L.....	41°C/W
Lead Temperature (Soldering, 10s)	260°C
ESD Susceptibility	
HBM	1000V
MM	100V



ESD SENSITIVITY CAUTION

ESD damage can range from subtle performance degradation to complete device failure. Precision integrated circuits may be more susceptible to damage because very small parametric changes could cause the device not to meet its published specifications.

(1) Stresses above these ratings may cause permanent damage. Exposure to absolute maximum conditions for extended periods may degrade device reliability. These are stress ratings only, and functional operation of the device at these or any other conditions beyond those specified is not implied.

(2) Input terminals are diode-clamped to the power-supply rails. Input signals that can swing more than 0.3V beyond the supply rails should be current-limited to 10mA or less.

PACKAGE/ORDERING INFORMATION

PRODUCT	ORDERING NUMBER	TEMPERATURE RANGE	PACKAGE LEAD	PACKAGE MARKING	PACKAGE OPTION
RS2099	RS2099XTQC16	-40°C ~125°C	QFN-3x3-16L	RS2099	Tape and Reel,3000
RS2099	RS2099XTSS16	-40°C ~125°C	TSSOP-16	RS2099	Tape and Reel,3000

ELECTRICAL CHARACTERISTICS
 $V+ = 5.0\text{ V}$, $T_A = -40^\circ\text{C}$ to 125°C (unless otherwise noted)

PARAMETER	SYMBOL	CONDITIONS	V+	T _A	MIN	TYP	MAX	UNITS
ANALOG SWITCH								
Analog Signal Range	V_{NO} , V_{NC} , V_{COM}			FULL	0		V+	V
On-Resistance	R_{ON}	V_{NO} or $V_{NC} = V+/2$, $I_{COM} = -10\text{mA}$, Switch ON, See Figure 1	5V	+25°C		0.6	1.0	Ω
				FULL			1.2	Ω
			3.3V	+25°C		1.0	1.5	Ω
				FULL			1.7	Ω
On-Resistance Match Between Channels	ΔR_{ON}	V_{NO} or $V_{NC} = V+/2$, $I_{COM} = -10\text{mA}$, Switch ON, See Figure 1	5V	+25°C		0.04	0.1	Ω
				FULL			0.12	Ω
			3.3V	+25°C		0.04	0.1	Ω
				FULL			0.12	Ω
On-Resistance Flatness	$R_{FLAT(ON)}$	$0 \leq (V_{NO} \text{ or } V_{NC}) \leq V+/2$, $I_{COM} = -10\text{mA}$, Switch ON, See Figure 1	5V	+25°C		0.18	0.3	Ω
				FULL			0.4	Ω
			3.3V	+25°C		0.54	0.7	Ω
				FULL			0.8	Ω
NC,NO OFF Leakage Current	$I_{NC(OFF)}$, $I_{NO(OFF)}$	V_{NO} or $V_{NC} = 0.3\text{V}$, $V+/2$ $V_{COM} = V+/2$, 0.3V See Figure 2	1.8 to 5.5V	FULL			1	μA
NC,NO,COM ON Leakage Current	$I_{NC(ON)}$, $I_{NO(ON)}$, $I_{COM(ON)}$	V_{NO} or $V_{NC} = 0.3\text{V}$, Open $V_{COM} = \text{Open}$, 0.3V See Figure 2	1.8 to 5.5V	FULL			1	μA
DIGITAL CONTROL INPUTS⁽¹⁾								
Input High Voltage	V_{INH}		5V	FULL	1.5			V
			3.3V	FULL	1.3			V
Input Low Voltage	V_{INL}		5V	FULL			0.6	V
			3.3V	FULL			0.5	V
Input Leakage Current	I_{IN}	$V_{IN} = V_{IO}$ or 0	1.8 to 5.5V	FULL			1	μA

(1) All unused digital inputs of the device must be held at V_{IO} or GND to ensure proper device operation.

ELECTRICAL CHARACTERISTICS (continued)
 $V_+ = 5.0\text{ V}$, TEMP= -40°C to 125°C (unless otherwise noted)

PARAMETER	SYMBOL	CONDITIONS	V+	TEMP	MIN	TYP	MAX	UNITS
DYNAMIC CHARACTERISTICS								
Turn-On Time	t_{ON}	$V_{COM} = V_+$, $R_L = 300\Omega$, $C_L = 35\text{pF}$, See Figure 5	5V	+25°C		50		ns
			3.3V			50		
Turn-Off Time	t_{OFF}	$V_{COM} = V_+$, $R_L = 300\Omega$, $C_L = 35\text{pF}$, See Figure 5	5V	+25°C		15		ns
			3.3V			17		
Break-Before-Make Time Delay	t_{BBM}	$V_{NO1} = V_{NC1} = V_{NO2} = V_{NC2} = 3\text{V}$, $R_L = 300\Omega$, $C_L = 35\text{pF}$, See Figure 6	5V	+25°C		10		ns
			3.3V			11		
Off Isolation	O_{ISO}	$R_L = 50\Omega$, Switch OFF, See Figure 8	f = 10MHz	+25°C		-68		dB
			f = 1MHz	+25°C		-86		dB
-3dB Bandwidth	BW	Switch ON, $R_L = 50\Omega$ See Figure 7		+25°C		30		MHz
NC,NO OFF Capacitance	$C_{NC(OFF)}$, $C_{NO(OFF)}$	V_{NC} or $V_{NO}=V_+/2$ or GND, Switch OFF See Figure 4		+25°C		80		pF
NC,NO,COM ON Capacitance	$C_{NC(ON)}$, $C_{NO(ON)}$, $C_{COM(ON)}$	V_{NC} or $V_{NO}=V_+/2$ or GND, Switch ON See Figure 4		+25°C		350		pF
POWER REQUIREMENTS								
Power Supply Range	V_+			FULL	1.8		5.5	V
Power Supply Current	I_+	$V_{IN} = \text{GND or } V_+$	5.5V	FULL			1	μA

TYPICAL CHARACTERISTICS

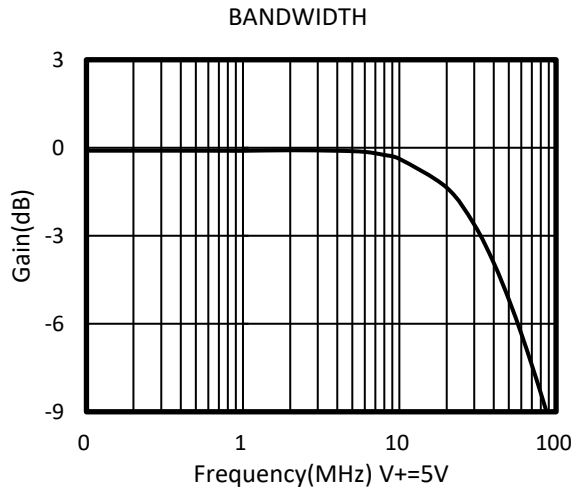
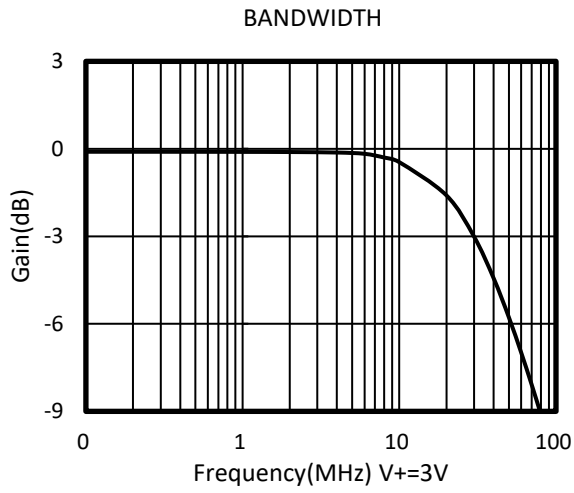

Typical ron as a Function of Input Voltage (VI) for VI = 0 to V+

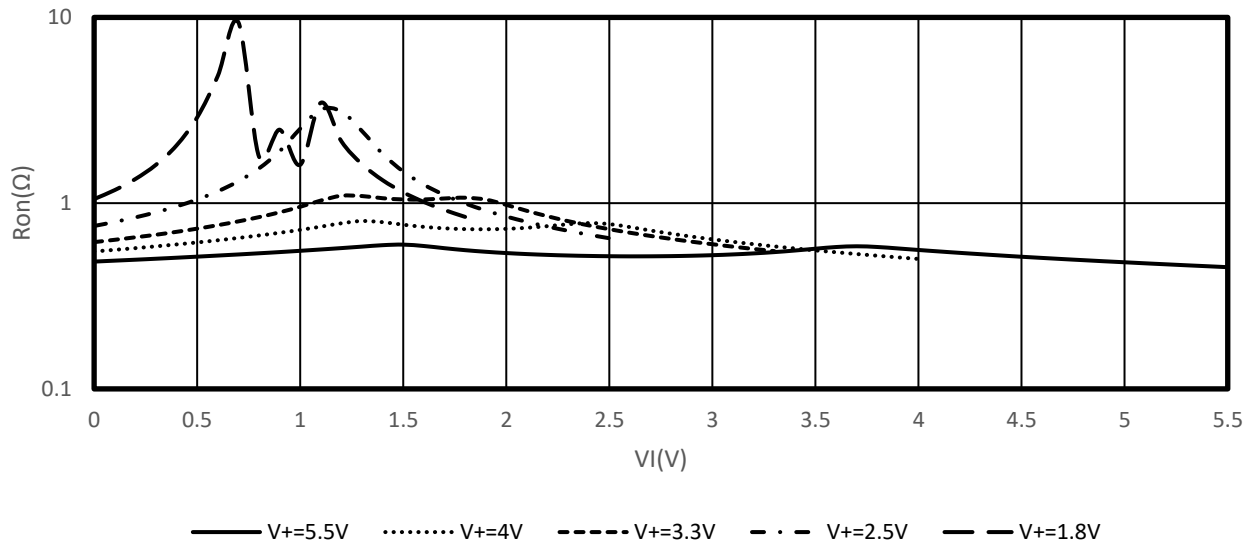

Parameter Measurement Information

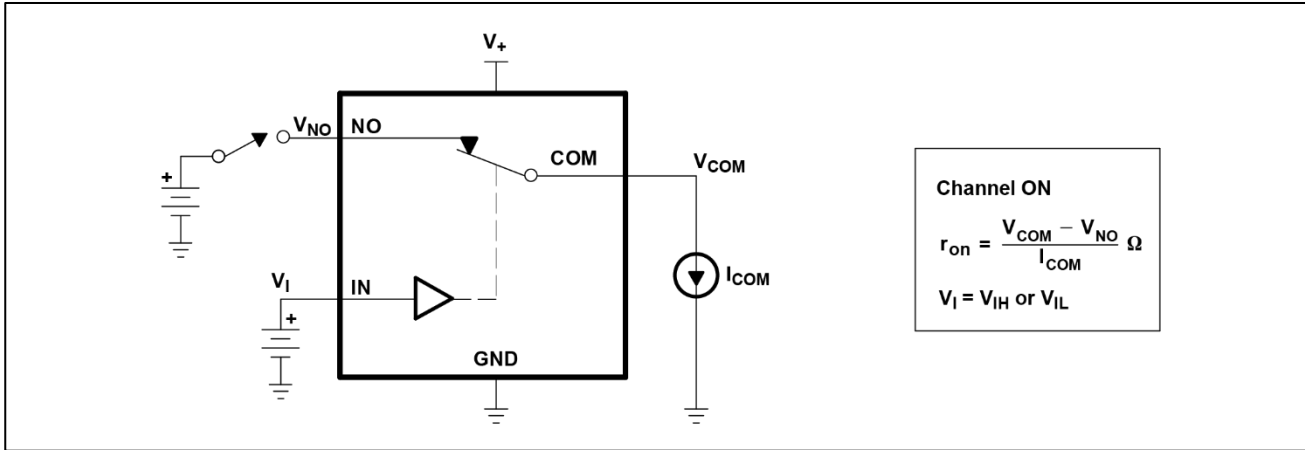

Figure 1.ON-State Resistance (r_{on})

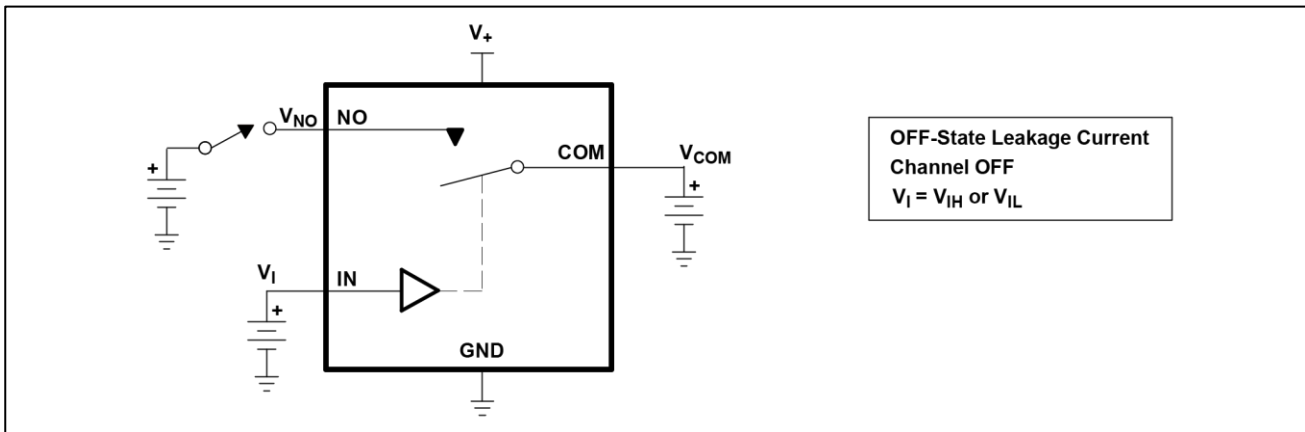

Figure 2.OFF-State Leakage Current ($I_{COM(OFF)}$, $I_{NO(OFF)}$)

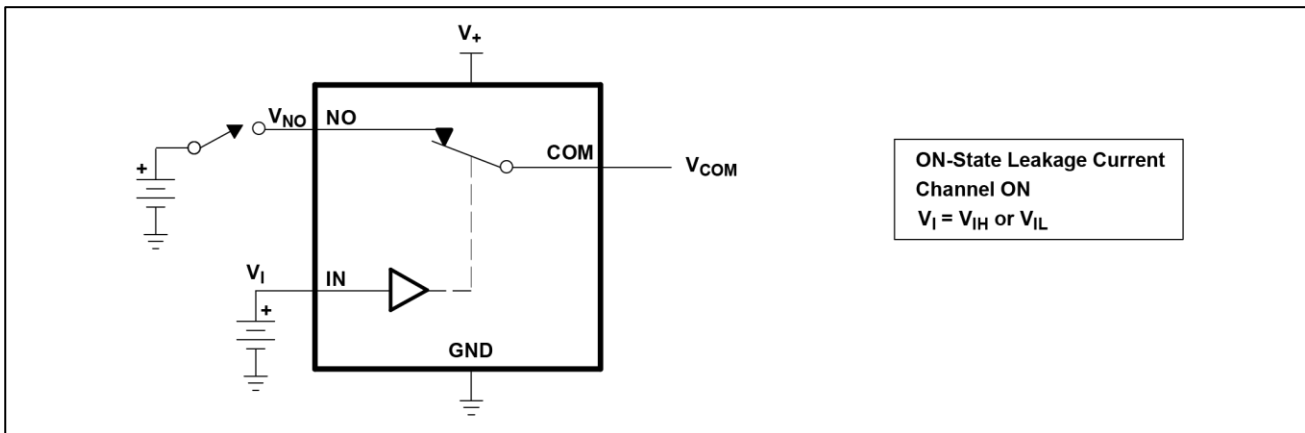

Figure 3.ON-State Leakage Current ($I_{COM(ON)}$, $I_{NO(ON)}$)

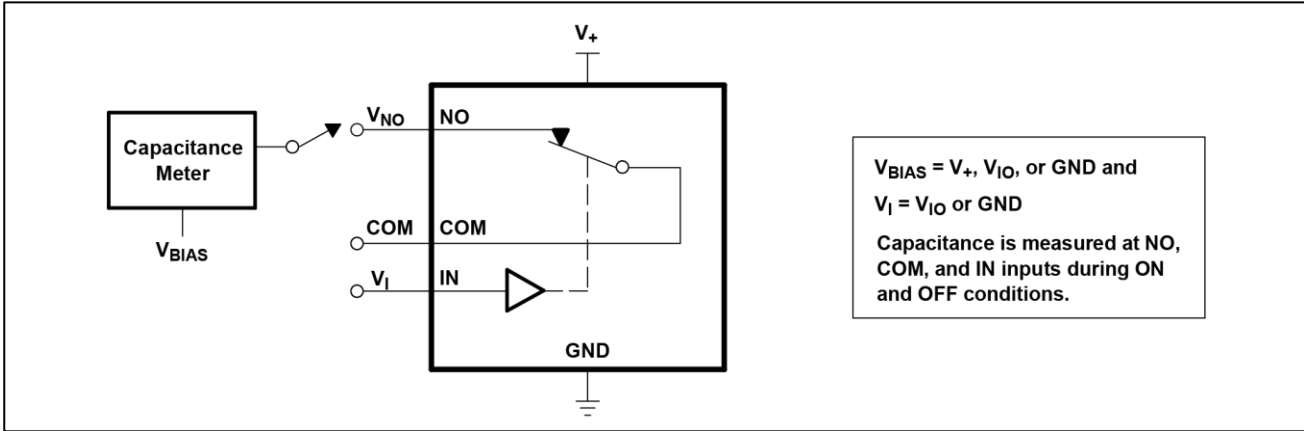

Figure 4. Capacitance (C_I , $C_{COM(OFF)}$, $C_{COM(ON)}$, $C_{NO(OFF)}$, $C_{NO(ON)}$)

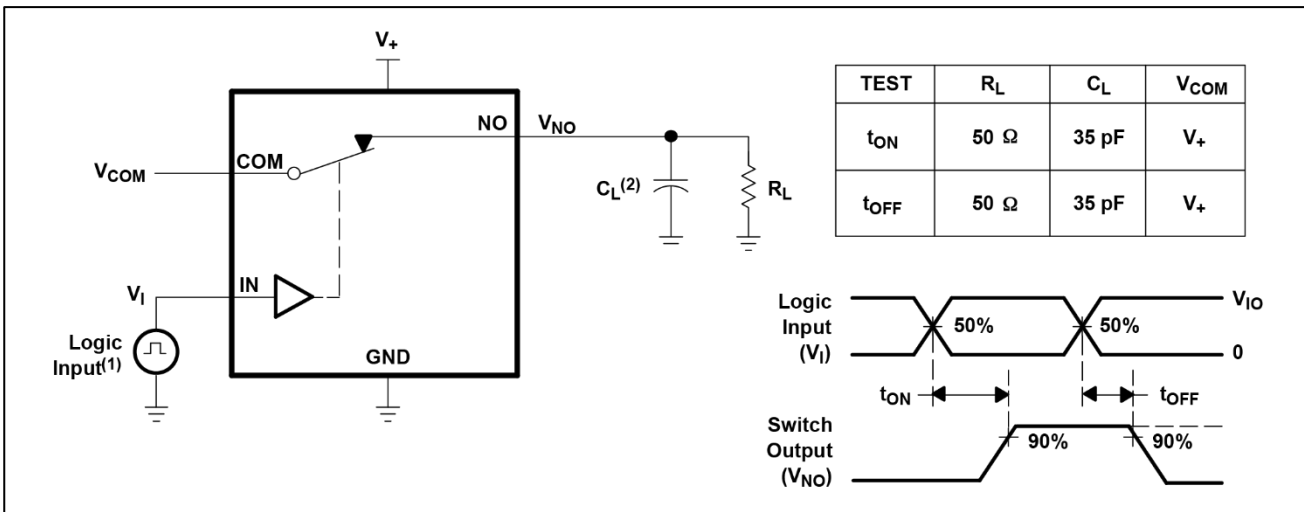

Figure 5. Turn-On (t_{ON}) and Turn-Off Time (t_{OFF})

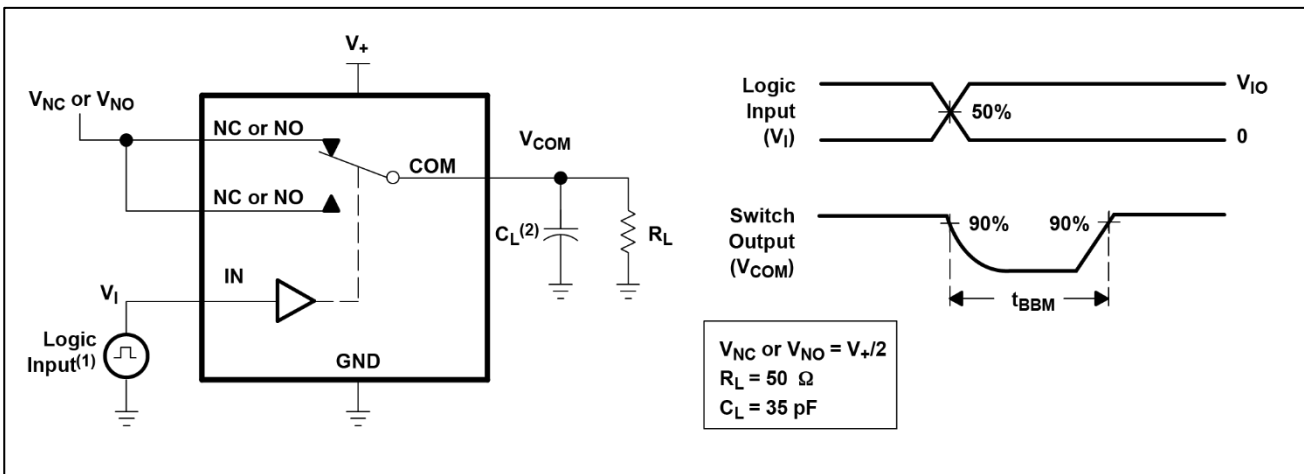

Figure 6. Break-Before-Make Time (t_{BBM})

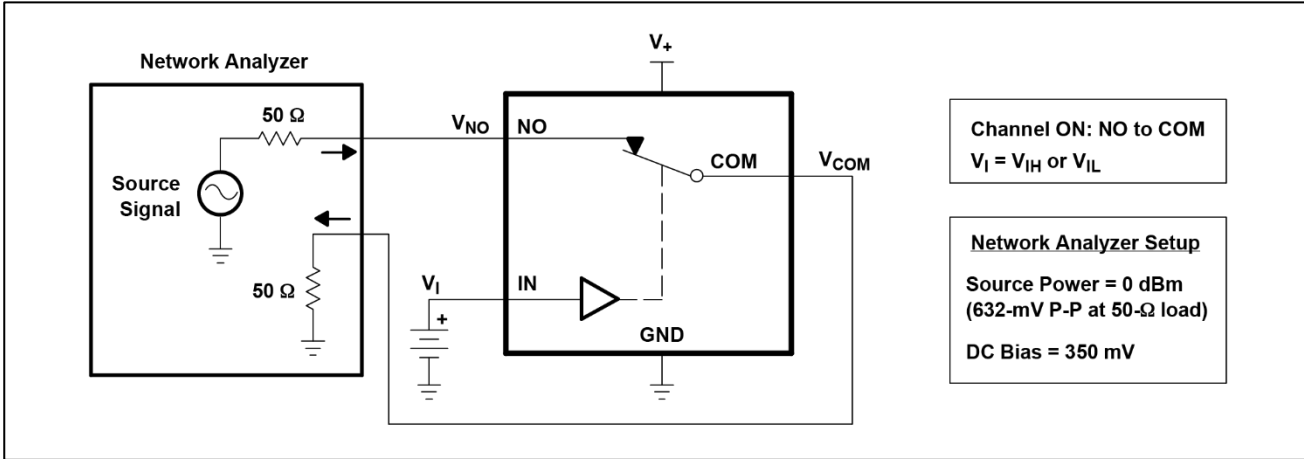

Figure 7. Bandwidth (BW)

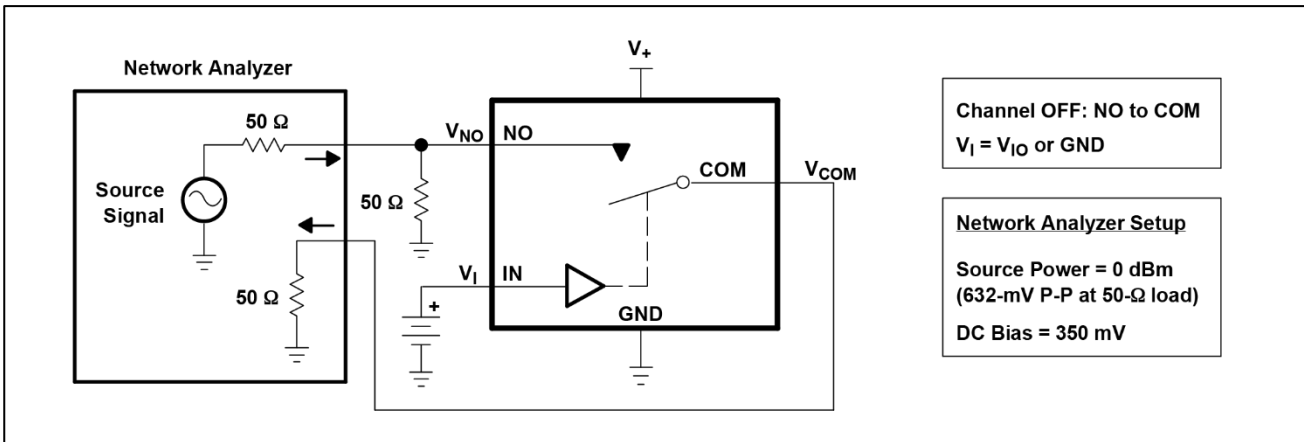

Figure 8. OFF Isolation (O_{iso})

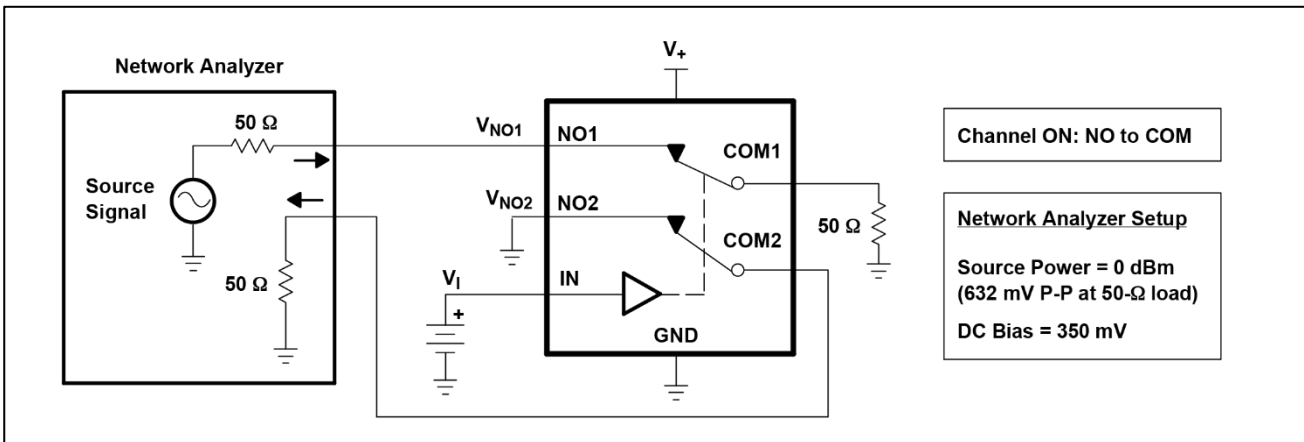

Figure 9. Crosstalk (X_{TALK})

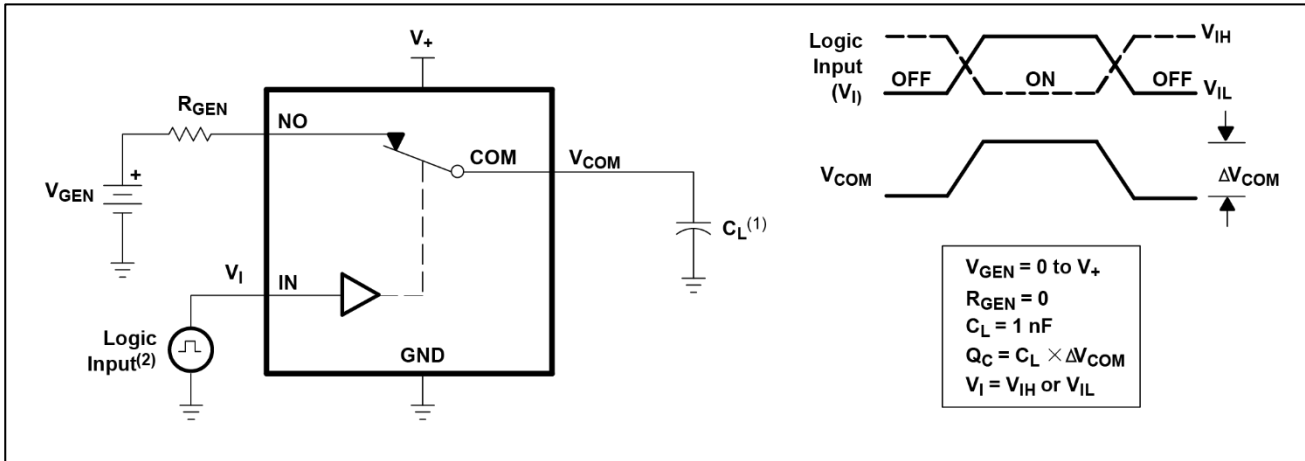

Figure 10.Charge Injection (Q_c)

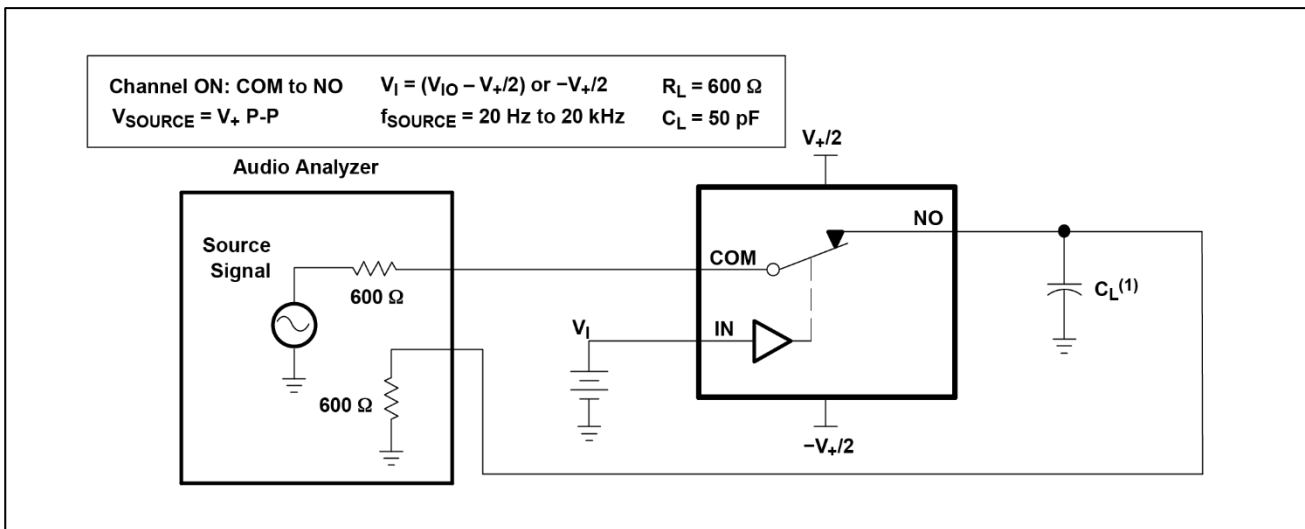
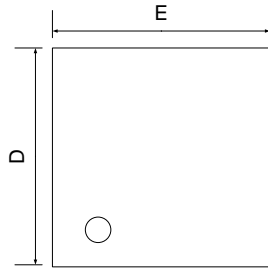
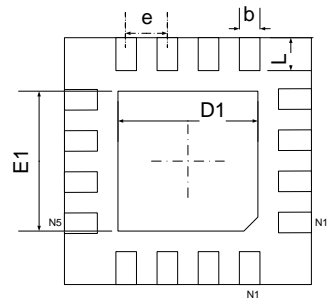

Figure11.Total Harmonic Distortion (THD)

PACKAGE OUTLINE DIMENSIONS
QFN-3x3-16L

TOP VIEW



BOTTOM VIEW

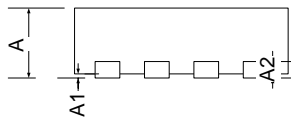

SIDE VIEW

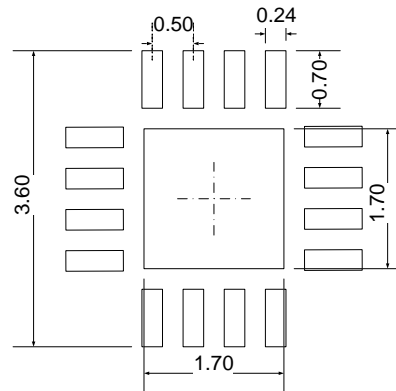

RECOMMENDED LAND PATTERN (Unit: mm)

Symbol	Dimensions In Millimeters		Dimensions In Inches	
	Min	Max	Min	Max
A	0.700	0.800	0.028	0.031
A1	0.000	0.050	0.000	0.002
A2	0.203		0.008	
b	0.180	0.300	0.007	0.012
D	2.900	3.100	0.114	0.122
D1	1.600	1.800	0.063	0.071
E	2.900	3.100	0.114	0.122
E1	1.600	1.800	0.063	0.071
e	0.500 TYP		0.020 TYP	
L	0.300	0.500	0.012	0.020

TSSOP-16

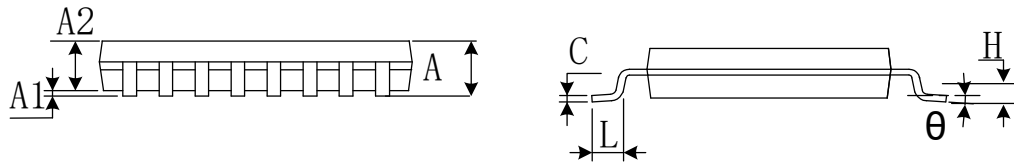
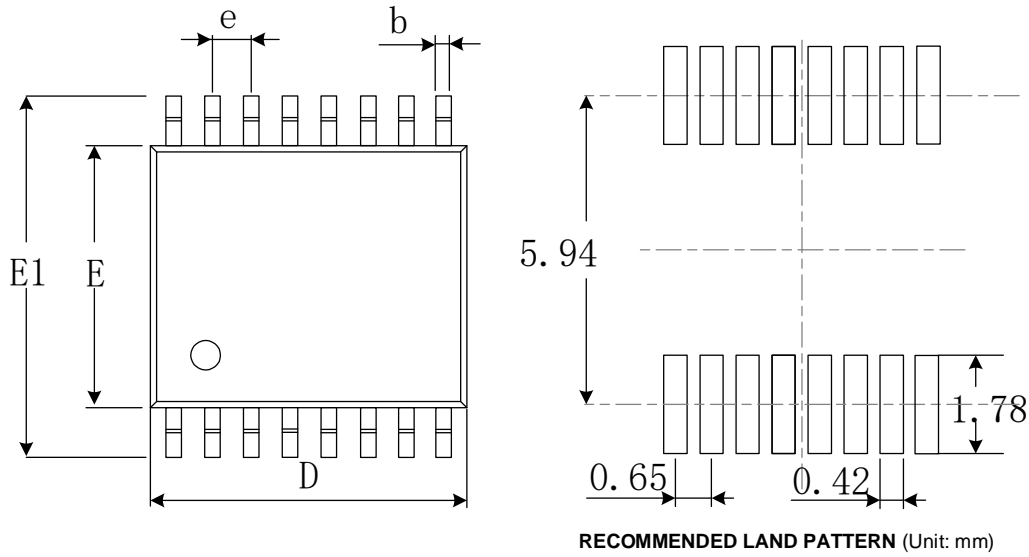

Symbol	Dimensions In Millimeters		Dimensions In Inches	
	Min	Max	Min	Max
A		1.200		0.047
A1	0.050	0.150	0.002	0.006
A2	0.800	1.050	0.031	0.041
b	0.190	0.300	0.007	0.012
c	0.090	0.200	0.004	0.008
D	4.860	5.100	0.191	0.201
E	4.300	4.500	0.169	0.177
E1	6.200	6.600	0.244	0.260
e	0.650(BSC)		0.026(BSC)	
L	0.500	0.700	0.02	0.028
H	0.25TYP		0.01TYP	
θ	1°	7°	1°	7°