

DIO3202B

USB2.0 High-Speed and Audio Switch with Negative Swing Capacity

Features

- Low Ron Audio/USB analog switch
- Low USB Con: 5pF
- Negative Signal Swing Capable
- Low Audio Distortion
- USB Switch -3dB Bandwidth: 720MHz
- High Crosstalk and Off-isolation
- Voltage Supply Operation: 2.7 to 5.5V
- 5.5V Tolerant on COM pin
- Green Packaged: DQFN10

Applications

- Cell-Phone/PDA
- MP3/MP4/PMP
- Portable Instrumentation
- Battery Powered Communications
- Computer Peripherals

Descriptions

The DIO3202B is dual SPDT (Single Pole/Double Throw) switch which combines low distortion audio and accurate USB2.0 high-speed data signal switching in the same low voltage device. This architecture is designed to allow negative signal passing as low as 2V below ground. When a voltage is detected on V_{BUS} , DIO3202B will immediately switch to USB mode.

DIO3202B provide package with Green or RoHS tiny 10L package, and operates over a temperature range of -40°C to 85°C.

Block Diagram

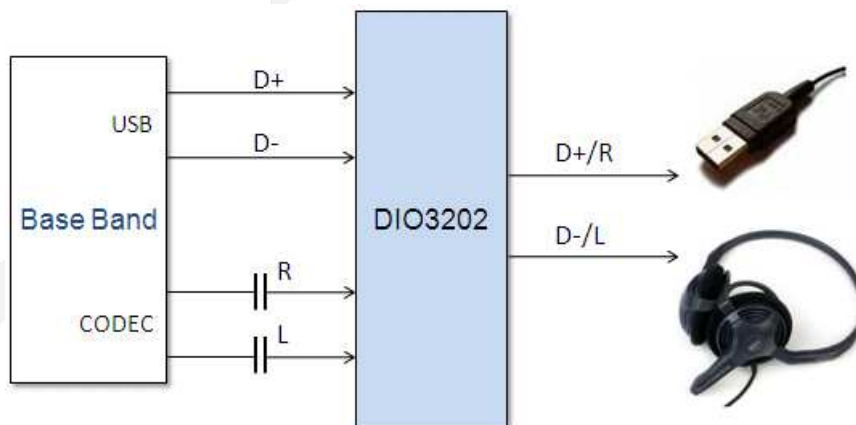

Ordering Information

| Order Part Number | Top Marking | | T_A | Package | |
|-------------------|-------------|-------|--------------|---------|-------------------|
| DIO3202BLP10 | YWGG | Green | -40 to +85°C | DQFN-10 | Tape & Reel, 3000 |

Pin Assignment

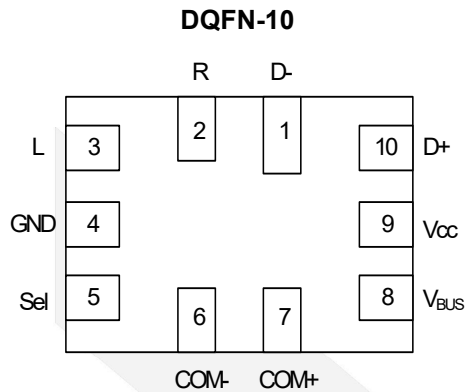

Figure 1 Top View

Pin Descriptions

| Pin Name | Direction | Description |
|-----------------------|-----------|------------------------|
| D+, D- / R, L | I/O | Data / Audio Port |
| V _{Bus} | I | Switch Select |
| COM+ / COM- | I/O | Data/Audio Common Port |
| Sel | I | Control Input |
| V _{cc} / GND | P | Power |

Truth Table

| Sel | V _{Bus} | L, R | D+, D- | Function |
|------|------------------|------|--------|-----------------------|
| Low | Low | ON | OFF | L=COM+, R=COM- |
| Low | High | OFF | ON | D+=COM+, D-=COM- |
| High | Low | OFF | OFF | Low power mode |
| High | High | ON | OFF | Audio Override on USB |



DIO3202B

USB2.0 High-Speed and Audio Switch with Negative Swing Capacity

Absolute Maximum Ratings

Stresses beyond those listed under "Absolute Maximum Rating" may cause permanent damage to the device. These are stress ratings only and functional operation of the device at these or any other condition beyond those indicated in the operational sections of the specifications is not implied. Exposure to absolute maximum rating conditions for extended periods may affect device reliability.

| Symbol | Parameter | Rating | Unit | |
|---------------|----------------------------------|-------------|------|----|
| V_{CC} | Supply Voltage | -0.5 to 6.5 | V | |
| V_{BUS} | V_{BUS} Control Input Voltage | -0.5 to 6.5 | V | |
| V_{IN} | A_{SEL} Control Input Voltage | -0.5 to 6.5 | V | |
| V_{SW} | USB Path Analog Signal Voltage | -0.5 to 6.5 | V | |
| | Audio Path Analog Signal Voltage | -2.5 to 6.5 | | |
| | Storage Temperature | -65 to 150 | °C | |
| I_{IN} | A_{SEL} Control Input Current | 5 | μA | |
| | V_{BUS} Control Input Current | 5 | | |
| I_{SW_CON} | Analog Signal Continuous Current | ±100 | mA | |
| I_{SW_PK} | Analog Signal Peak Current | ±500 | mA | |
| ESD | HBM, JEDEC: JESD22-A114 | I/O to GND | 4 | kV |
| | | Others | 8 | |

Recommend Operating Conditions

The Recommended Operating Conditions table defines the conditions for actual device operation. Recommended Operating conditions are specified to ensure optimal performance to the datasheet specifications. DIOO does not Recommend exceeding them or designing to Absolute Maximum Ratings.

| Symbol | Parameter | Rating | Unit |
|----------|------------------------------------|----------------|------|
| V_{CC} | Supply Voltage | 2.7 to 5.5 | V |
| V_{IN} | V_{BUS} Control Input Voltage | 0 to 5.5 | V |
| | A_{SEL} Control Input Voltage | 0 to V_{CC} | |
| V_{SW} | USB to COM Analog Signal Voltage | 0 to V_{CC} | V |
| | Audio to COM Analog Signal Voltage | -2 to V_{CC} | |
| T_A | Operating Temperature Range | -40 to 85 | °C |



DIO3202B

USB2.0 High-Speed and Audio Switch with Negative Swing Capacity

DC Electrical Characteristics

All typical value are at $T_A = 25^\circ\text{C}$ unless otherwise specified.

| Symbol | Parameter | Conditions | Min. | Typ. | Max. | Unit |
|---|---|---|------|------|-----------|---------------|
| CONTROL INPUT ($T_A=25^\circ\text{C}$, $V_{CC}=3.3\text{V}$) | | | | | | |
| V_{IH} | A_{SEL} Control Input High Voltage | $V_{CC}=2.7-4.2\text{V}$ | 1.4 | | | V |
| V_{IL} | A_{SEL} Control Input Low Voltage | $V_{CC}=2.7-4.2\text{V}$ | | | 0.5 | V |
| I_{IN} | A_{SEL} Control Input Leakage Current | $0 \leq V_{SW} \leq V_{CC}$ | -2 | | 2 | μA |
| V_{IH} | V_{BUS} Control Input High Voltage | $V_{CC}=2.7-4.2\text{V}$ | 1.4 | | | V |
| V_{IL} | V_{BUS} Control Input Low Voltage | $V_{CC}=2.7-4.2\text{V}$ | | | 0.7 | V |
| I_{IN} | V_{BUS} Control Input Leakage Current | $0 \leq V_{SW} \leq V_{CC}$ | -2 | | 2 | μA |
| SUPPLY CURRENT AND LEAKAGE ($T_A=25^\circ\text{C}$, $V_{CC}=3.3\text{V}$) | | | | | | |
| I_{D+}, I_{D-} (OFF) | Off State Leakage | $V_{CC}=4.2\text{V}$, $V_{BUS} = 0\text{V}$, $V_{SEL} = 4.2\text{V}$; $V_{COM-}, V_{COM+} = 0\text{V}, 4.2\text{V}$; $V_{D+}, V_{D-} = 4.2\text{V}, 0\text{V}$; V_L and $V_R = \text{float}$ | | | ± 80 | nA |
| $I_{COM(ON)}$ | On State Leakage | $V_{CC}=4.2\text{V}$; $V_{COM-}, V_{COM+} = 0\text{V}, 4.2\text{V}$; $V_{D+}, V_{D-} = \text{float}$; $V_L, V_R = \text{float}$ | | | ± 100 | nA |
| I_{CC} | Quiescent Supply | | | 95 | 120 | μA |
| AUDIO SWITCHES (R, L) ($T_A=25^\circ\text{C}$, $V_{CC}=3.3\text{V}$) | | | | | | |
| R_{ON} | On Resistance | $I_{ON}=40\text{mA}$, $V_{SW}=-0.85$ to 0.85V | | 2 | 2.5 | Ω |
| R_{FLAT} | On Resistance Flatness | $I_{ON}=40\text{mA}$, $V_{SW}=-0.85$ to 0.85V | | 0.6 | 1 | Ω |
| ΔR_{ON} | On Resistance Matching | $I_{ON}=40\text{mA}$, $V_{SW}=-0.85$ to 0.85V | | 0.05 | | Ω |
| USB SWITCHES (D+, D-) ($T_A=25^\circ\text{C}$, $V_{CC}=3.3\text{V}$) | | | | | | |
| R_{ON} | On Resistance | $I_{ON}=8\text{mA}$, $V_{SW}=0.4\text{V}$ | | 4 | 4.5 | Ω |
| R_{FLAT} | On Resistance Flatness | $I_{ON}=8\text{mA}$, $V_{SW}=0.4\text{V}$ | | 0.4 | 0.6 | Ω |



DIO3202B

USB2.0 High-Speed and Audio Switch with Negative Swing Capacity

Electrical Characteristics (Continued)

All typical value are at 25°C unless otherwise specified.

| Symbol | Parameter | Conditions | Min. | Typ. | Max. | Unit |
|---|-------------------------------------|--|------|------|------|----------|
| ΔR_{ON} | On Resistance Matching | $I_{ON}=8mA, V_{SW}=0.4V$ | | 0.05 | | Ω |
| AC Parameter ($T_A=25^\circ C, V_{CC}=3.3V, R_L=50\Omega, C_L=5pF$, unless otherwise specified) | | | | | | |
| t_{ON} | USB Turn-on Time | $V_{CC}=2.7V, R_L=50\Omega, C_L=10pF$ | | 60 | | ns |
| t_{OFF} | USB Turn-off Time | $V_{CC}=2.7V, R_L=50\Omega, C_L=10pF$ | | 15 | | ns |
| t_{ON} | Audio Turn-on Time | $V_{CC}=2.7V, R_L=50\Omega, C_L=10pF$ | | 75 | | ns |
| t_{OFF} | Audio Turn-off Time | $V_{CC}=2.7V, R_L=50\Omega, C_L=10pF$ | | 40 | | ns |
| T_{BBM} | Break Before Make Time | $V_{CC}=2.7V$ | | 7 | | μs |
| BW | -3dB Bandwidth USB Channel | $R_L=50\Omega$ | | 720 | | MHz |
| OIRR | OFF-Isolation | $V_{CC}=3.3V, R_L=32\Omega, f = 20Hz$ to 20kHz | | 105 | | dB |
| X_{TALK} | USB Crosstalk | $V_{CC}=3.3V, R_L=50\Omega, f=100kHz$ | | -100 | | dB |
| X_{TALK} | Audio Crosstalk | $V_{CC}=3.3V, V_{BUS}=float, V_{SEL}=3.3V, R_L=32\Omega, f=20Hz$ to 20kHz, V_R or $V_L = 0.707V_{RMS} (2V_{PP})$ | | -100 | | dB |
| THD+N | Total Harmonic Distortion + Noise | $V_{BUS}=0V, V_{SEL}=3.3V, R_L=32\Omega, f=20Hz$ to 20kHz, $V_{COM}=2V_{PP}$ | | 0.05 | | % |
| CAPACITANCE ($T_A=25^\circ C, V_{CC}=3.3V, R_L=50\Omega, C_L=5pF, f=1MHz, A_{SEL}=0V$, unless otherwise specified) | | | | | | |
| C_{IN} | A_{SEL} Control Input Capacitance | $V_{CC}=0V$ | | 2 | | pF |
| C_{ON} | USB ON Capacitance | $f=1MHz, V_{CC}=3.3V, V_{BUS}=4.2V, V_{SEL}=0V, V_{D-}$ or $V_{D+} = V_{COMX} = 0V$ | | 5 | | pF |
| C_{ON} | Audio ON Capacitance | $V_{BUS}=0V, V_{SEL}=3.3V$ | | 9 | | pF |
| C_{OFF} | USB OFF Capacitance | $V_{BUS}=0V, V_{SEL}=3.3V$ | | 3 | | pF |
| C_{OFF} | Audio OFF Capacitance | $V_{BUS}=4.2V, V_{SEL}=0V$ | | 4 | | pF |

Applications Design Guide

DIO3202B is used in applications where the slim and thin smart phone designs are expected. By sharing the USB connector between USB2.0 data lines and audio headphone outputs, the designers can eliminate the using of bulky headphone jacks. Meanwhile, using the mini-USB connectors as audio outputs allows the end users to reduce the cost to buy too many different types of cell phone accessories.

DIO3202B unique architectures allow the part to allow the part to have constant R_{on} , R_{on} (flatness) and THD performance independent of V_{cc} supply value. So in some applications such as mobile cell phone designs, if the designers want to achieve the lowest standby power consumption when the battery is turned OFF, it is highly recommended that DIO3202B be powered by 2.8V, no need of being powered by 4.3V directly. This will help designers to be freed from the complex logic designs to ensure the part will get into sleep mode.

DIO3202B's control pins are 1.8V control logic compatible, so the parts can be controlled by baseband processor GPIO directly without worrying about the level shifting issues. Regarding high speed signal integrity, DIO3202B is recommended to be placed as close as possible to the USB controller outputs to reduce the signal reflection under high speed mode (480Mbps). In the meanwhile, the V_{cc} pins of DIO3202B is required to have decoupling capacitors to reduce the supply ripples.

The below is the DIO3202B USB 2.0 high speed (480Mbps) eye diagram compliance test under near-end mode (most challenging mode).

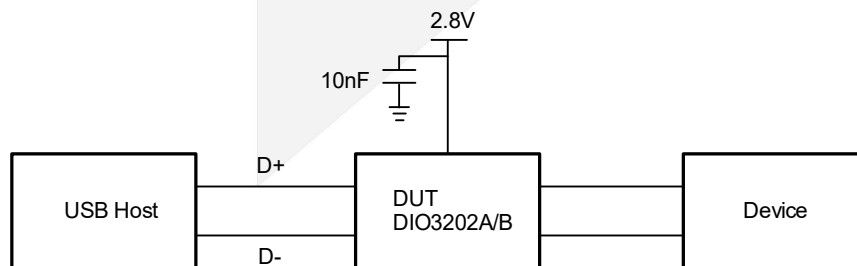

Figure 2. USB2.0 high speed eye diagram test circuit



DIO3202B

DIO3202B USB 2.0 high speed (480Mbps) eye pattern

T_A= 25°C, V_{CC}= 2.8V, unless otherwise specified.

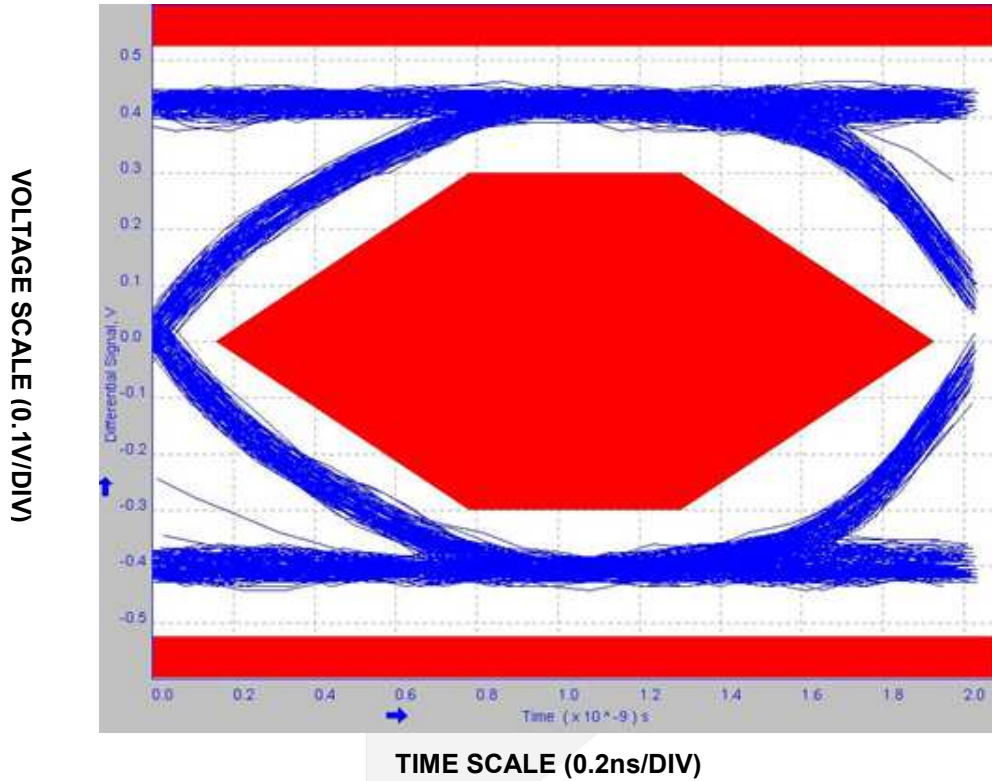

Figure 3. Eye Pattern: 480Mbps with USB switch In signal path



USB2.0 High-Speed and Audio Switch with Negative Swing Capacity

CONTACT US

Dioo is a professional design and sales corporation for high-quality and performance analog semiconductors. The company focuses on industry markets, such as, cell phone, handheld products, laptop, and medical equipment and so on. Dioo's product families include analog signal processing and amplifying, LED drivers and charger IC. Go to <http://www.dioo.com> for a complete list of Dioo product families.

For additional product information, or full datasheet, please contact with our Sales Department or Representatives.

